

TAG: EF-1, EF-2, EF-3, EF-12



GREENHECK

Building Value in Air.

Downblast Centrifugal Roof Exhaust Fans

PN 471558

Installation, Operation and Maintenance Manual

Please read and save these instructions. Read carefully before attempting to assemble, install, operate or maintain the product described. Protect yourself and others by observing all safety information. Failure to comply with instructions could result in personal injury and/or property damage! Retain instructions for future reference.

Model G Direct Drive

Model G is a direct drive downblast centrifugal exhaust fan. These fans are specifically designed for roof mounted applications exhausting relatively clean air. Performance capabilities range up to 4,300 cfm (7,305 m³/hr) and up to 1 in. wg (249 Pa) of static pressure. The maximum continuous operating temperature is 180°F (82°C). G models are available in sixteen sizes with nominal wheel diameter ranging from 8 to 18 inches (203 to 457 mm) (060 - 180 unit sizes). Each fan shall bear a permanently affixed manufacturer's engraved metal nameplate containing the model number and individual serial number. All fans are UL/cUL listed Standard 705.

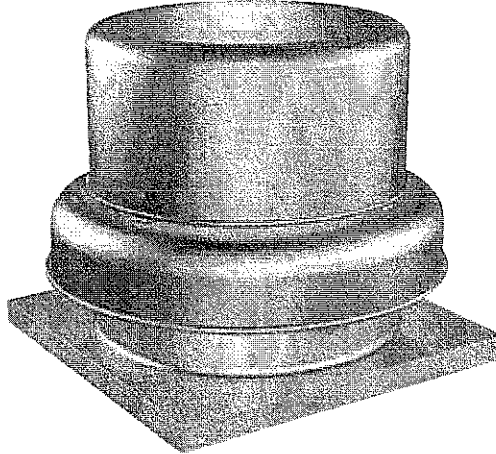

Model GB Belt Drive

GB Model Fans are belt drive downblast centrifugal exhaust fans. These fans are specifically designed for roof mounted applications exhausting relatively clean air. Performance capabilities range up to 44,700 cfm (75,950 m³/hr) and up to 2.5 in. wg (623 Pa) of static pressure. The maximum continuous operating temperature is 180°F (82°C). GB models are available in twenty sizes with nominal wheel diameters ranging from 11 to 54 inches (279 to 1372 mm) (071-540 unit sizes). Each fan shall bear a permanently affixed manufacturer's nameplate containing the model number and individual serial number. All fans are UL/cUL listed Standard 705.

General Safety Information

Only qualified personnel should install this fan. Personnel should have a clear understanding of these instructions and should be aware of general safety precautions. Improper installation can result in electric shock, possible injury due to coming in contact with moving parts, as well as other potential hazards. Other considerations may be required if high winds or seismic activity are present. If more information is needed, contact a licensed professional engineer before moving forward.

DANGER

Always disconnect, lock and tag power source before installing or servicing. Failure to disconnect power source can result in fire, shock or serious injury.

CAUTION

When servicing the fan, motor may be hot enough to cause pain or injury. Allow motor to cool before servicing.

CAUTION

Precaution should be taken in explosive atmospheres.

1. Follow all local electrical and safety codes, as well as the National Electrical Code (NEC) and the National Fire Protection Agency (NFPA), where applicable. Follow the Canadian Electric Code (CEC) in Canada.
2. The rotation of the wheel is critical. It must be free to rotate without striking or rubbing any stationary objects.
3. Motor must be securely and adequately grounded.
4. Do not spin fan wheel faster than max cataloged fan RPM. Adjustments to fan speed significantly effects motor load. If the fan RPM is changed, the motor current should be checked to make sure it is not exceeding the motor nameplate amps.
5. Do not allow the power cable to kink or come in contact with oil, grease, hot surfaces or chemicals. Replace cord immediately if damaged.
6. Verify that the power source is compatible with the equipment.
7. Never open access doors to a duct while the fan is running.

Receiving

Upon receiving the product check to make sure all items are accounted for by referencing the bill of lading to ensure all items were received. Inspect each crate for shipping damage before accepting delivery. Notify the carrier if any damage is noticed. The carrier will make notification on the delivery receipt acknowledging any damage to the product. All damage should be noted on all the copies of the bill of lading which is countersigned by the delivering carrier. A Carrier Inspection Report should be filled out by the carrier upon arrival and reported to the Traffic Department. If damaged upon arrival, file a claim with carrier. Any physical damage to the unit after acceptance is not the responsibility of Greenheck Fan Corporation.

Unpacking

Verify that all required parts and the correct quantity of each item have been received. If any items are missing, report shortages to your local representative to arrange for obtaining missing parts. Sometimes it is not possible that all items for the unit be shipped together due to availability of transportation and truck space. Confirmation of shipment(s) must be limited to only items on the bill of lading.

Handling

G Direct Drive

Lift unit on to the roof utilizing hooks under the lip of the shroud. Evenly space the hooks around the shroud using a minimum of four lifting straps. Use a spreader bar to ensure the straps do not come in contact with the unit (see figure 1).

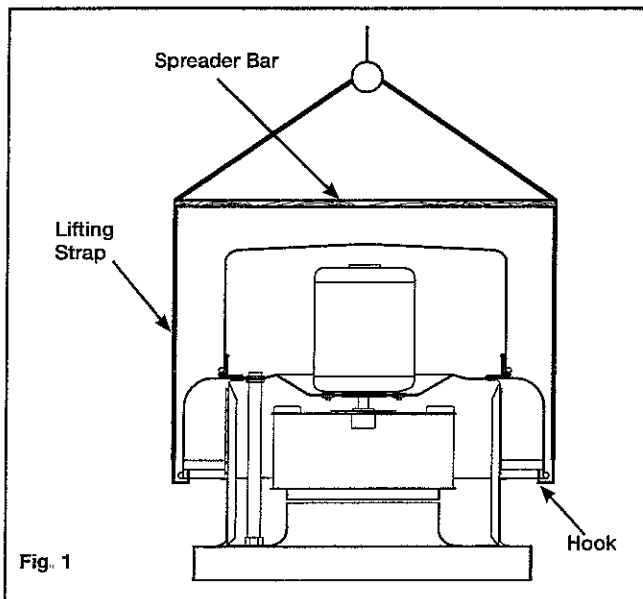

GB Belt Drive

When lifting the unit on to the roof, use either the four lifting points on the drive frame or the two lifting points on the bearing plate if present (see figure 2 for lifting points). Access to the drive frame is accomplished by removing the screws pointed out in figure 3. The cover can then be removed and placed on a flat surface in an area protected from strong winds.

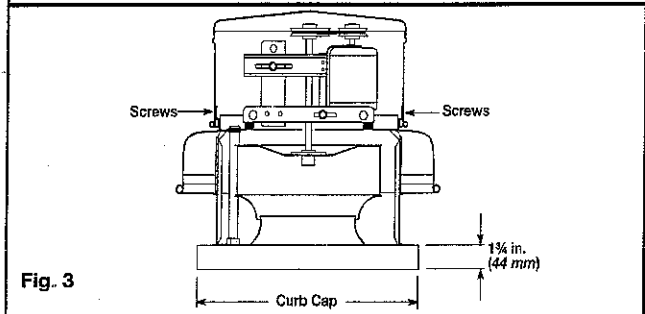
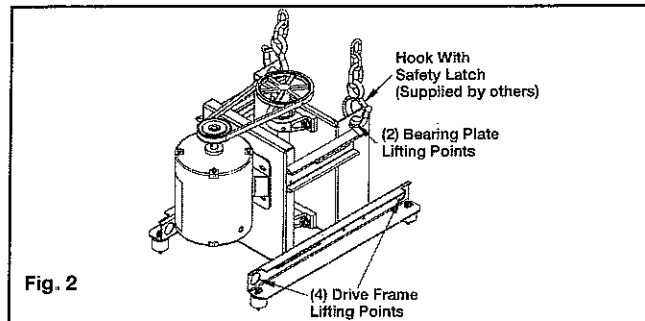

When G/GB unit is on the roof, move fan to desired location using lifting points and fasten securely through mounting holes in base. Shims may be necessary depending upon roofing material thickness.

The motor amperage and voltage ratings must be checked for compatibility to supply voltage prior to final electrical connection. For G/GB installations, the electrical supply should be routed through the conduit chase located between the curb cap and the bottom of the motor compartment. Wiring must conform to local and national codes.

Storage

Fans are protected against damage during shipment. If the unit cannot be installed and operated immediately, precautions need to be taken to prevent deterioration of the unit during storage. The user assumes responsibility of the fan and accessories while in storage. The manufacturer will not be responsible for damage during storage. These suggestions are provided solely as a convenience to the user.

Indoor

The ideal environment for the storage of fans and accessories is indoors, above grade, in a low humidity atmosphere which is sealed to prevent the entry of blowing dust, rain or snow. Temperatures should be evenly maintained between 30° to 110°F (-1° to 43°C) (wide temperature swings may cause condensation and "sweating" of metal parts). All accessories must be stored indoors in a clean, dry atmosphere.

Remove any accumulations of dirt, water, ice or snow and wipe dry before moving to indoor storage. To avoid "sweating" of metal parts allow cold parts to reach room temperature. To dry parts and packages use a portable electric heater to get rid of any moisture buildup. Leave coverings loose to permit air circulation and to allow for periodic inspection.

The unit should be stored at least 3½ inches (89 mm) off the floor on wooden blocks covered with moisture proof paper or polyethylene sheathing. Aisles between parts and along all walls should be provided to permit air circulation and space for inspection.

Outdoor

Fans designed for outdoor applications may be stored outdoors, if absolutely necessary. Roads or aisles for portable cranes and hauling equipment are needed.

The fan should be placed on a level surface to prevent water from leaking into the fan. The fan should be elevated on an adequate number of wooden blocks so that it is above water and snow levels and has enough blocking to prevent it from settling into soft ground. Locate parts far enough apart to permit air circulation, sunlight and space for periodic inspection. To minimize water accumulation, place all fan parts on blocking supports so that rain water will run off.

Do not cover parts with plastic film or tarps as these cause condensation of moisture from the air passing through heating and cooling cycles.

Fan wheels should be blocked to prevent spinning caused by strong winds.

Inspection and Maintenance During Storage

While in storage, inspect fans once per month. Keep a record of inspection and maintenance performed.

If moisture or dirt accumulations are found on parts, the source should be located and eliminated. At each inspection, rotate the wheel by hand ten to fifteen revolutions to distribute lubricant on motor. If paint deterioration begins, consideration should be given to touch-up or repainting. Fans with special coatings may require special techniques for touch-up or repair.

Machined parts coated with rust preventive should be restored to good condition promptly if signs of rust occur. Immediately remove the original rust preventive coating with petroleum solvent and clean with lint-free cloths. Polish any remaining rust from surface with crocus cloth or fine emery paper and oil. Do not destroy the continuity of the surfaces. Thoroughly wipe clean with Tectyl® 506 (Ashland Inc.) or the equivalent. For hard to reach internal surfaces or for occasional use, consider using Tectyl® 511M Rust Preventive, WD-40® or the equivalent.

Removing From Storage

As fans are removed from storage to be installed in their final location, they should be protected and maintained in a similar fashion until the fan equipment goes into operation.

Installation

WARNING

Installation, troubleshooting and parts replacement is to be performed only by qualified personnel.

WARNING

Disconnect power before installing or servicing.

Typical Roof Mounting Installation

1. On the roof surface, cut an appropriate sized hole and follow manufacturer's instructions on curb installation. Caulk and flash the curb to ensure a water tight seal.
2. If unit is equipped with a backdraft damper, it should be installed now.
3. Remove motor cover. Access to the motor compartment is accomplished by removing the screws as shown in figure 3.
4. Only on GB Belt Drive fans. On the drive frame use the lifting lugs to lift and place the unit on top of roof curb. (Refer to figure 2 on page 2).
5. Secure fan to curb using a minimum of eight lug screws, metal screws or the suitable fasteners. Shims may be required depending upon curb installation and roofing material.
6. Verify power line wiring is de-energized before connecting fan motor to power source.
7. Connect power supply wiring to the motor as indicated on the motor nameplate or terminal box cover. Check the power source for compatibility with the requirements of your equipment.
8. Check fan wheel for free rotation, re-center if necessary.
9. Check all fasteners for tightness.
10. Mount and wire safety disconnect switch under motor cover. Wire control switches at ground level, refer to figure 4.
12. Replace motor cover.

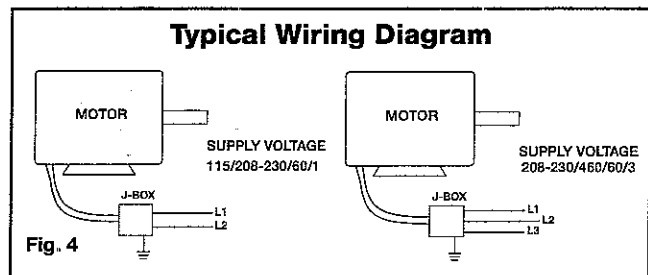

G - Direct Drive

Model	Curb Cap	Damper	Roof Opening	*Approx. Weight
G 060, 065, 070, 075	17 (432)	8 (203)	10½ (267)	18 (8)
G 080, 085, 090, 095	17 (432)	10 (254)	12½ (318)	26 (12)
G 101, 121	19 (483)	12 (305)	14½ (368)	43 (20)
G 131, 141	22 (559)	16 (406)	18½ (470)	58 (26)
G 150	26 (660)	16 (406)	18½ (470)	59 (27)
G 160, 170	30 (762)	18 (457)	20½ (521)	81 (37)
G 180	30 (762)	18 (457)	20½ (521)	118 (54)

GB - Belt Drive

Model	Curb Cap	Damper	Roof Opening	*Approx. Weight
GB 071, 081, 091	19 (483)	12 (305)	14½ (368)	58 (26)
GB 101, 101HP	19 (483)	12 (305)	14½ (368)	63 (29)
GB 121	19 (483)	12 (305)	14½ (368)	66 (30)
GB 131	19 (483)	12 (305)	14½ (368)	67 (30)
GB 141, 141HP	22 (559)	16 (406)	18½ (470)	83 (38)
GB 161, 161HP	22 (559)	16 (406)	18½ (470)	89 (40)
GB 180, 180HP	30 (762)	18 (457)	20½ (521)	125 (57)
GB 200, 200HP	30 (762)	18 (457)	20½ (521)	138 (63)
GB 220, 240, 220HP	34 (864)	24 (610)	26½ (673)	158 (72)
GB 260	40 (1016)	30 (762)	32½ (826)	305 (138)
GB 300, 300HP	40 (1016)	30 (762)	32½ (826)	320 (145)
GB 330	46 (1168)	36 (914)	38½ (978)	385 (175)
GB 360, 360HP	46 (1168)	36 (914)	38½ (978)	403 (183)
GB 420	52 (1321)	42 (1067)	44½ (1130)	495 (225)
GB 480	52 (1321)	48 (1219)	50½ (1283)	623 (283)
GB 500	64 (1626)	54 (1372)	56½ (1435)	687 (312)
GB 540	64 (1626)	54 (1372)	56½ (1435)	748 (339)

- All dimensions are in inches (millimeters). *Approximate weight shown in pounds (kilograms) is the largest cataloged Open Drip Proof motor.
- The roof curb should be ½ in. (38 mm) less than the curb cap to allow for roofing and flashing.

G Direct Drive

Fig. 5 - Typical Roof Mounting Installation

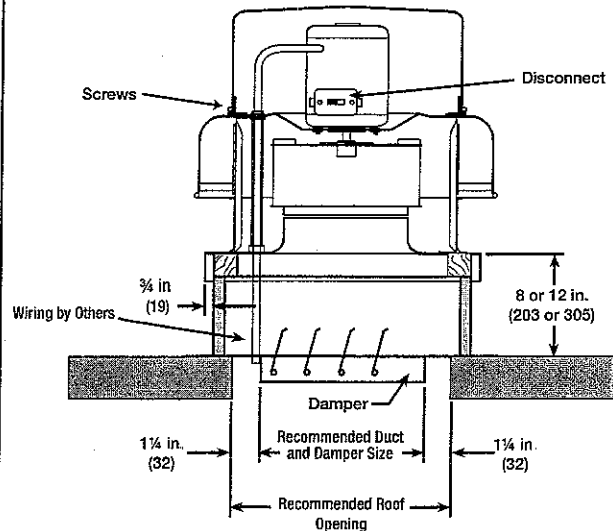

GB Belt Drive

Fig. 6 - Typical Roof Mounting Installation

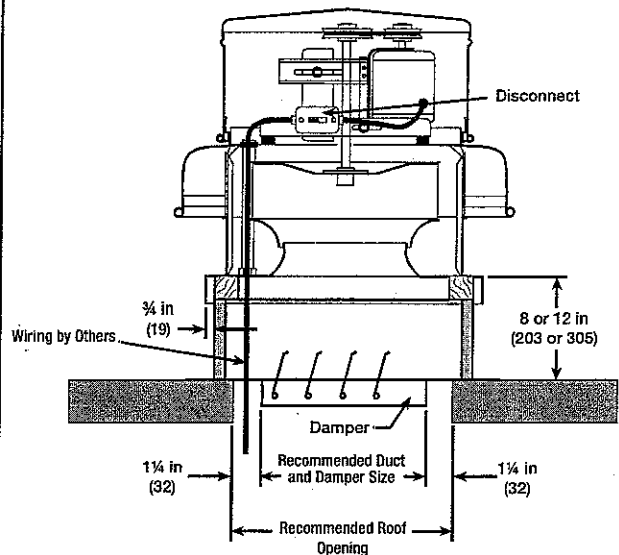

Pre-Starting Checks

1. Check all fasteners and set screws for tightness. The wheel should rotate freely and be aligned as shown in figure 7 on page 5.
2. Wheel position is preset and the unit is test run at the factory. Movement may occur during shipment and realignment may be necessary.
3. Only G unit - Centering height alignment can be accomplished by loosening the set screws in the wheel and moving the wheel to the desired position.
4. Only GB unit - Centering can be accomplished by loosening the bolts holding the drive frame to the shock mounts and repositioning the drive frame.
5. Only GB unit - Wheel and inlet cone overlap can be adjusted by loosening the set screws in the wheel and moving the wheel to the desired position.
6. Only GB unit - Fan RPM should be checked and verified with a tachometer.
7. Check wheel rotation (viewing from the shaft side) by momentarily energizing the unit. On a G unit the rotation should correspond to the rotation decal on the unit, see figure 8. On a GB unit rotation should be clockwise as shown in figure 8 and correspond to rotation decal on the unit. If wheel rotation is incorrect reverse two of the wiring leads or check motor wiring for single phase.

Wheel Overlap and Gap Dimensions

Model	G - Overlap in. (mm)	H - Gap in. (mm)
G 060-095	-	3/32 (2)
G 101-180	-	1/4 (6)
GB 071-161	1/4 (6)	-
GB 180-240	3/8 (10)	-
GB 260-540	1/2 (13)	-

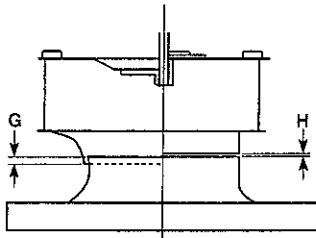
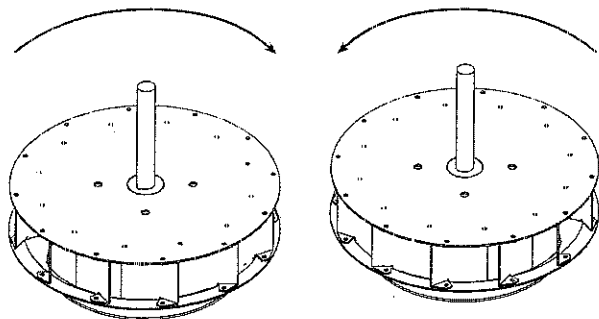

Fig. 7

Wheel Rotation



Clockwise
Airflow
G 060-131
All GB Models

Counterclockwise
Airflow
G 141-180

Fig. 8

WARNING

Correct direction of wheel rotation is critical. Reversed rotation will result in poor air performance, motor overloading and possible burnout.

WARNING

The fan has been checked for mechanical noises at the factory prior to shipment. If mechanical noise should develop, suggested corrective actions are offered in the Troubleshooting section.

IMPORTANT

Over tightening will cause excessive bearing wear and noise. Too little tension will cause slippage at startup and uneven wear.

Model GB

Pre-Starting Belt Tension Checks

- Always loosen tension enough to install belts without stretching, see figure 9.
- For units with two groove pulleys, adjust so the tension is equal in both belts.

Belts

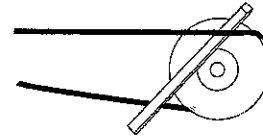

Do not force belt(s). Forcing the belt(s) will break the cords and cause belt failure

Fig. 9

- If adjustments are made, it is very important to check the pulleys for proper alignment. Misaligned pulleys lead to excessive belt wear vibration, noise and power loss, see figure 10.

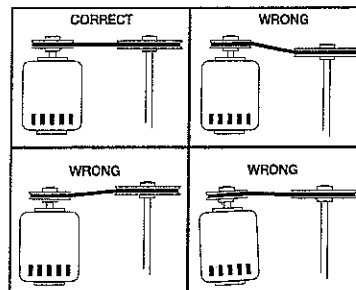

Fig. 10

- Belt tension can be adjusted by loosening four fasteners on the drive frame, see figure 11. The motor plate slides on the slotted adjusting arms and drive frame angles in the same manner.

Fasteners

(4) *Fasteners

*Identical fasteners on opposing side must also be loosened.

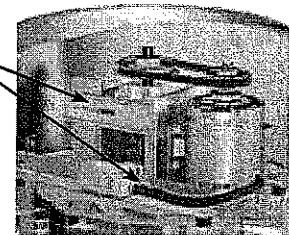

Fig. 11

- 12a. Sizes 071-161: Belts should be tensioned just enough to prevent slippage at full load.

Note: Belts should have a slight bow on the slack side while running at full load (see figure 12a).

- 12b. Sizes 180-540: Belt tension should be adjusted to allow 1/64 in. (0.397 mm) of deflection per inch of belt span. For example, a 15 in. (381 mm) belt span should have 1/64 in. (0.234 mm) (or about 1/4 in. (6 mm)) of deflection with moderate thumb pressure at mid-point between pulleys (see figure 12b).

Deflection

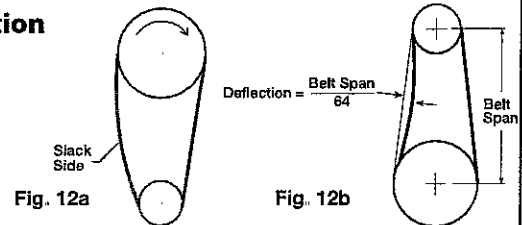

Fig. 12a

Fig. 12b

- The adjustable motor pulley is factory set for the RPM specified. Speed can be increased by closing or decreased by opening the adjustable motor pulley.

14. Any increase in speed represents a substantial increase in the horsepower required by the unit.
15. Motor amperage should always be checked to avoid serious damage to the motor when speed is varied.

Operation: G / GB

1. Before starting up or operating fan, check all fasteners for tightness. In particular, check the setscrews in wheel hub.
2. While in the OFF position or before connecting the fan to power, turn the fan wheel by hand to be sure it is not striking the venturi or any obstacle.
3. Start the fan and shut it off immediately to check rotation of the wheel with directional arrow in the motor compartment.
4. When the fan is started, observe the operation and check for any unusual noises.
5. With the system in full operation and all ductwork attached, measure current input to the motor and compare with the nameplate rating to determine if the motor is operating under safe load conditions.
6. Keep inlets and approaches to fan clean and free from obstruction.

IMPORTANT

Adjust (tighten) belt tension after the first 24-48 hours of operation.

Inspection

Inspection of the fan should be conducted at the first 30 minute and 24 hour intervals of satisfactory operation.

30 Minute Interval

Inspect bolts, setscrews and motor mounting bolts. Adjust and tighten as necessary.

24 Hour Interval

Check all internal components. On GB unit only, inspect belt alignment and tension. Adjust and tighten as necessary.

Maintenance: G / GB

Installation and maintenance are to be performed only by qualified personnel who are familiar with local codes and regulations and who are experienced with this type of equipment.

Motor maintenance is generally limited to cleaning and lubrication (where applicable). Cleaning should be limited to exterior surfaces only. Removing dust buildup on motor housing ensures proper motor cooling.

WARNING

Always disconnect, lock and tag power source before servicing. Failure to disconnect power source can result in fire, shock or serious injury.

Greasing of motors is only intended when fittings are provided. Many fractional horsepower motors are permanently lubricated and should not be lubricated after installation. Motors supplied with grease fittings should be greased in accordance with manufacturers' recommendations. Where motor temperatures do not exceed 104°F (40°C), the grease should be replaced after 2,000 hours of running time as a general rule.

Wheels require very little attention when moving clean air. Occasionally, oil and dust may accumulate causing imbalance. When this occurs the wheel and housing should be cleaned to ensure smooth and safe operation.

All fasteners should be checked for tightness each time maintenance checks are performed prior to restarting unit.

A proper maintenance program will help these units deliver years of dependable service.

CAUTION

Uneven cleaning of the wheel will produce an out of balance condition that will cause vibration in the fan.

WARNING

This unit should be made non-functional when cleaning the wheel or housing (fuses removed, disconnect locked off).

Belt/Bearing Maintenance GB Unit

1. Belts tend to stretch after a period of time. They should be checked periodically for wear and tightness. When replacing belts, use the same type as supplied with the unit.
2. Matched belts should always be used on units with multi-groove pulleys.
3. For belt replacement, loosen the tensioning device enough to allow removal of the belt by hand.
4. Once installed, adjust belts as shown in "Pre-Starting Checks."
5. Shaft bearings can be classified in two groups: relubricating and non-relubricating. All non-relubricating bearings on standard model GB fans are factory lubricated and require no further lubrication under normal use (between -20° to 180°F (-29° to 82°C) in a relatively clean environment).
6. On GB belt driven fans, the standard cast pillow block bearings are factory lubricated and are provided with external grease fittings. Annual lubrication is recommended, or more frequently if needed (see Table 2 on page 7). Do not over-grease. Use only one or two shots of lubricant with a hand gun. Maximum hand gun rating is 40 psi. Rotate bearings during lubrication where good safety practice permits. Caution should be employed to prevent over packing or contamination.
7. Grease fittings should be wiped clean. The unit should be in operation while lubricating. Extreme care should be used around moving parts.

8. Grease should be pumped in very slowly until a slight bead forms around the seal. A high grade lithium base grease should be used.
9. To ensure tightness, check pulley setscrews. Proper keys must be in keyways.
10. Fan RPM should not be readjusted. Only use pulleys of identical size and type when replacing pulleys.
11. During the first few months of operation check bearing set screws periodically to ensure tightness.
12. If unit is to be left idle for an extended period, remove belts and store in a cool, dry place to avoid premature belt failure.

Recommended Relubrication Frequency in Months

NOTE: If unusual environment conditions exist (extreme temperature, moisture or contaminants) more frequent lubrication is required.

A good quality lithium base grease, conforming to NLGI Grade 2 consistency, such as those listed here may be used.

Manufacturer	Grease (NLGI #2)
U.S. Electric Motors	Grease No. 83343
Chevron U.S.A. Inc	Chevron SRI Grease #2
Mobil Oil Corporation	Mobilith
	Mobil 532
Texaco, Inc.	Premium BRB #2
	Texaco Multifak #2
Amoco Oil Co.	Rykon Premium #2
Exxon	Unirex N2
Shell	B Shell Alvania #2

Table 2: Suggested Fan Bearing Greasing Intervals

Interval (months)	Type of Service
1 to 3	Heavy duty in dirty, dusty locations; high ambient temperatures; moisture laden atmosphere; vibration.
3 to 6	12 to 24 hours per day, heavy duty, or if moisture is present
6 to 12	8 to 16 hours per day in clean, relatively dry atmosphere
12 to 18	Infrequent operation or light duty in clean atmosphere

Fan Inlet Connections

In order to assure proper fan performance, caution must be exercised in fan placement and connection to the ventilation system. Obstructions, transitions, poorly designed elbows, improperly selected dampers, etc. can cause reduced performance, excessive noise and increased mechanical stress. For performance to be as published, the system must provide uniform and stable airflow into the fan.

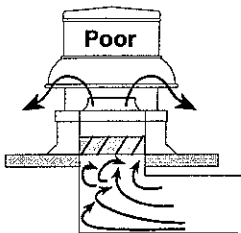

Dampers must open fully. Use motorized dampers in low airflow applications to reduce losses.

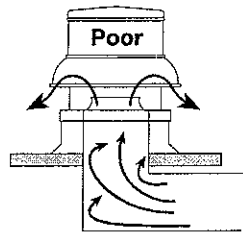

Avoid sharp turns or entrance conditions which cause uneven flow. Use turning vanes in elbows to reduce adverse effects.

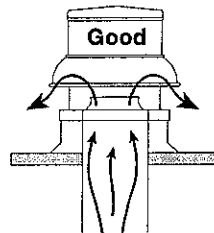

Provide uniform airflow at fan inlet to assure optimum performance.

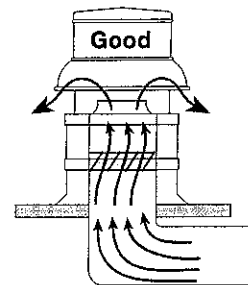

Provide uniform airflow at fan inlet and through the damper to assure optimum performance. The curb cap should be three wheel diameters from the radius. Use turning vanes in duct when possible.

Troubleshooting

WARNING: Before taking any corrective action, make certain unit is not capable of operation during repairs.

PROBLEM	CAUSE	CORRECTIVE ACTION
Excessive noise or vibration	Wheel rubbing inlet	Adjust wheel and/or inlet cone. Tighten wheel hub or bearing collars on shaft.
	V-belt drive	Tighten pulleys on motor/fan shaft. Adjust belt tension. Align pulleys properly, see page 5/figure 9-10. Replace worn belts or pulleys.
	Bearings	Replace defective bearing(s). Lubricate bearings. Tighten collars and fasteners.
	Wheel unbalance	Clean all dirt off wheel. Check wheel balance, rebalance in place if necessary.
	Bad bearings	Replace.
	Belts too tight or too loose	Adjust tension, see figure 12a-b.
	Wheel improperly aligned and rubbing	Center wheel on inlet, see figure 7.
	Loose drive or motor pulleys	Align and tighten. See "Pre-Starting Checks", see page 5-6.
	Foreign objects in wheel or housing	Remove objects, check for damage or unbalance.
	Fan base not securely anchored	Secure properly.
	Motor hood loose and rattling	Tighten acorn nuts securing motor hood.
High horsepower	Defective or loose motor bearings	Replace motor with same frame size, RPM-HP
	Fan	Check rotation of wheel, see figure 8. Reduce fan speed.
Fan does not operate	Duct system	Resize ductwork. Check proper operation of face and bypass dampers. Check filters and access doors.
	Electrical supply	Check fuses/circuit breakers. Check for switches off. Check for correct supply voltage.
	Drive	Check for broken belts. Tighten loose pulleys.
Motor overloads or overheats	Motor	Assure motor is correct horsepower and not tripping overload protector.
	Lubrication	Check for excessive or insufficient grease in the bearing.
	Mechanical	Replace damaged bearing. Relieve excessive belt tension. Align bearings. Check for bent shaft.
	Belt slippage	Adjust tension or replace bad belts, see page 5-6.
	Over/Under line voltage	Contact power company.
	Incorrect wheel rotation	Check motor wiring, see figure 4.
	Wheel RPM too high	Check drives or slow down fan by opening variable pitch pulley on motor shaft.
	Undersized motor	Check motor ratings with catalog speed and air capacity chart.
Reduced airflow	Motor wired incorrectly	Check motor wiring to wiring diagram located on fan motor.
	System resistance too high	Check system: Proper operation of backdraft or control dampers, obstruction in ductwork, clean dirty filters.
	Unit running backwards	Correct as shown in figure 8.
	Excessive dirt buildup on wheels	Clean wheel.
	Improper wheel alignment	Center wheel on inlets, see Pre-Starting checks and figure 7.
	Dampers closed	Inspect and repair.
	Blocked duct/clogged filter	Clean or replace.
	Belt slippage	Replace and adjust tension.
Speed too slow	Check for correct drives.	

Parts List

NOTE

Each fan bears a manufacturer's nameplate with model number and serial number embossed. This information will assist the local Greenheck representative and the factory in providing service and replacement parts. Before taking any corrective action, make certain unit is not capable of operation during repairs.

CAUTION

A fan manufactured with an explosion resistant motor does not certify the entire unit to be explosion proof.

G Direct Drive Centrifugal Roof Exhaust Fan

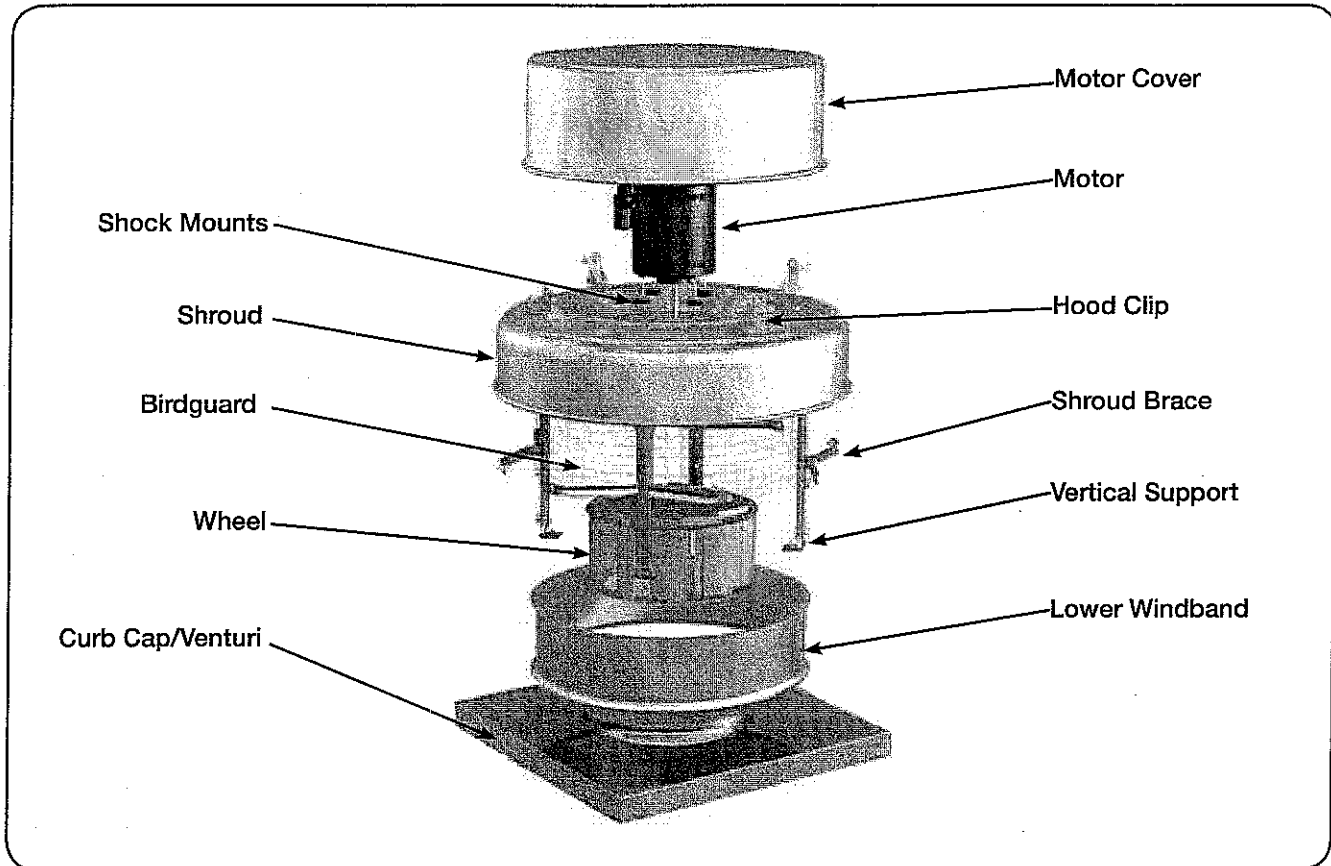

GB Belt Drive Centrifugal Roof Exhaust Fan

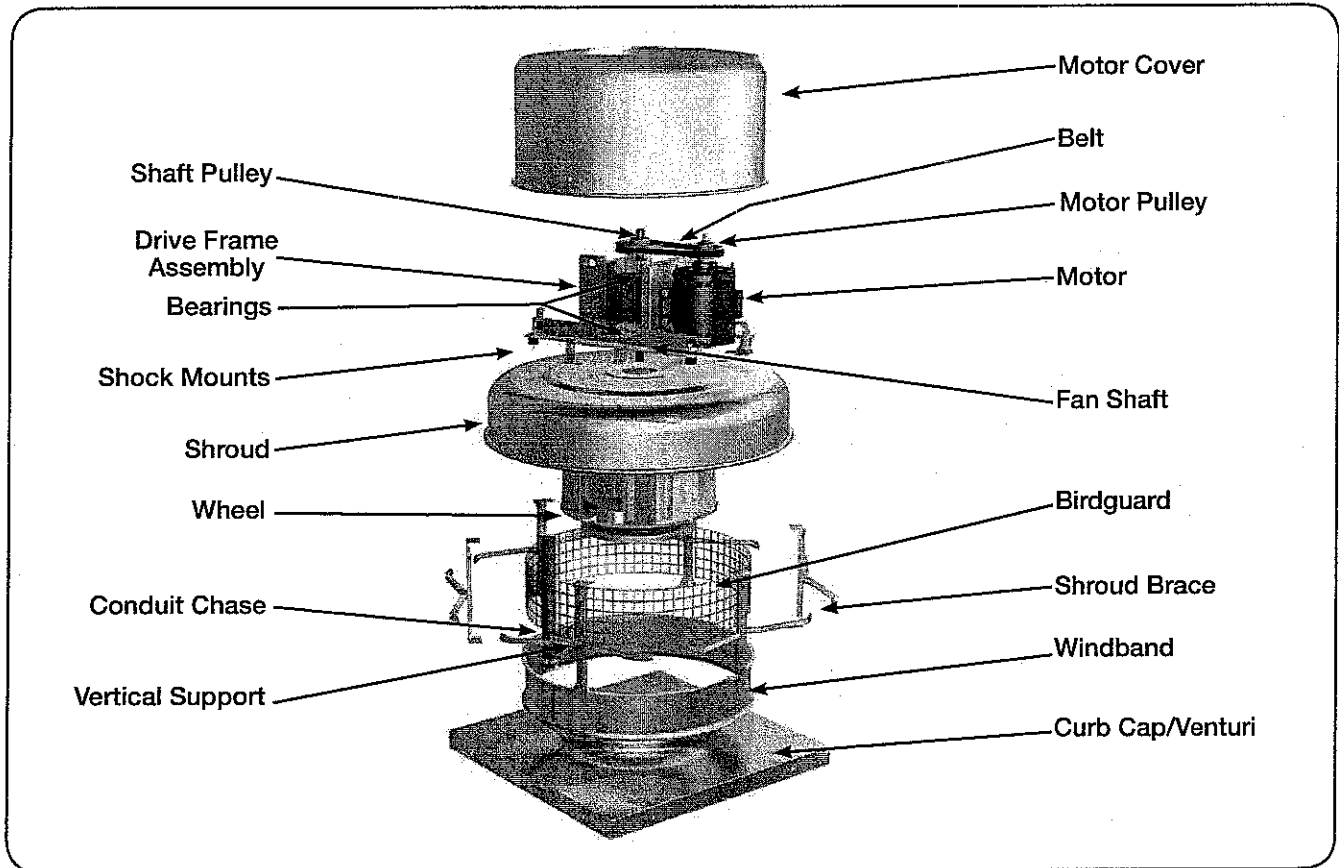

Roof Curb Installation

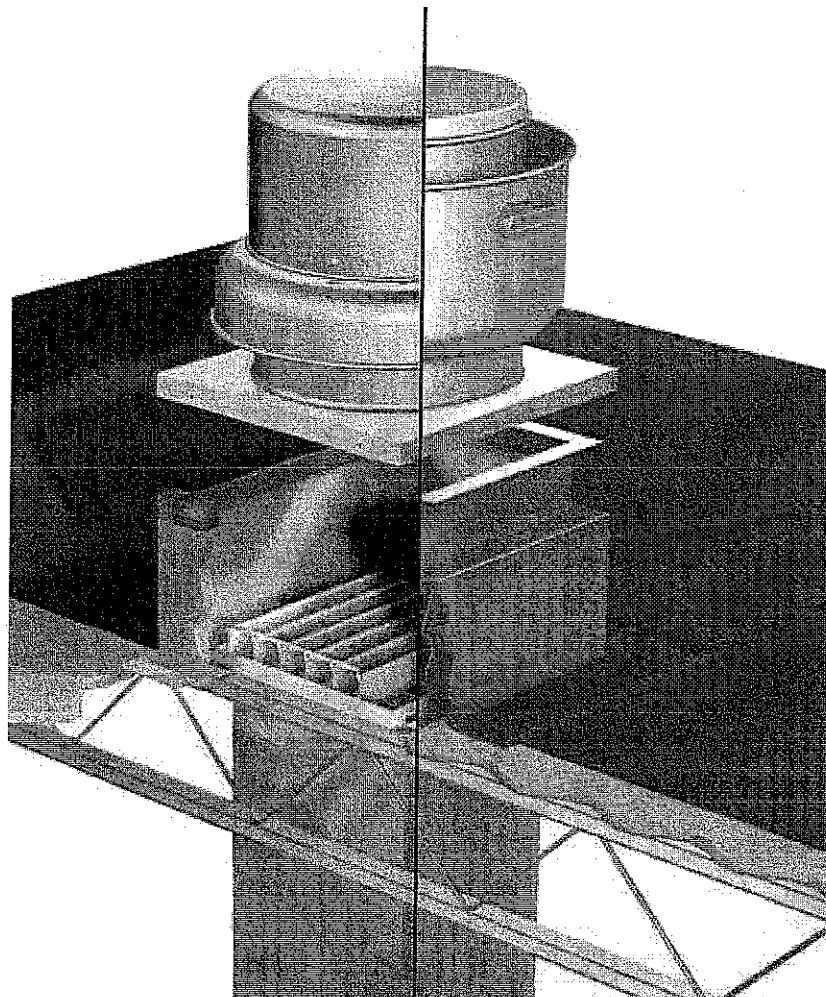

Warranty

Greenheck warrants this equipment to be free from defects in material and workmanship for a period of one year from the purchase date. Any units or parts which prove defective during the warranty period will be replaced at our option when returned to our factory, transportation prepaid. Motors are warranted by the motor manufacturer for a period of one year. Should motors furnished by Greenheck prove defective during this period, they should be returned to the nearest authorized motor service station. Greenheck will not be responsible for any removal or installation costs.

As a result of our commitment to continuous improvement, Greenheck reserves the right to change specifications without notice.

Greenheck Catalog G/GB provides additional information describing the equipment, fan performance, available accessories, and specification data.

AMCA Publication 410-96, Safety Practices for Users and Installers of Industrial and Commercial Fans, provides additional safety information. This publication can be obtained from AMCA International, Inc. at: www.amca.org.



Phone: (715) 359-6171 • Fax: (715) 355-2399 • E-mail: gfcinfo@greenheck.com • Website: www.greenheck.com