

THERMA-FUSER™

THERMALLY POWERED VAV DIFFUSER

INSTALLATION, BALANCING & MAINTENANCE



Models: **TF-C** VAV cooling only.
TF-CW VAV cooling and warm up heating.
TF-HC VAV cooling and VAV heating.
TF-D Manually adjustable blades.
TF-RA Return air.
 (See Fig. 1 for dimensions)

DAMAGED FREIGHT CLAIM PROCEDURE

When the diffusers are received, inspect for damage which may have occurred during shipment. If damage is evident, it should be noted on the carrier's freight bill. A written request for inspection by the carrier's agent should be made at once.

STORAGE

Cartons should always be stacked on end with the arrows on the cartons pointing up. Do not stack cartons flat on the sides. Excessive weight may cause damage to the diffusers.

Do not store for prolonged times at temperatures exceeding 130°F/56°C.

IDENTIFICATION

Diffusers are factory shipped one per carton. The model designation is on the diffuser and on the carton.

INSTALLATION PRECAUTIONS

When installing diffusers, make sure construction debris does not enter the diffuser or duct system.

Because the models TF-C, TF-CW and TF-HC control room temperature by sensing the room air induced up the center of the room, care should be taken not to disturb room air induction and entrainment. For example, location next to walls or dropped lights results in the reflection of primary air back at the Therma-Fuser diffuser and should be avoided. A three-way blow Therma-Fuser diffuser should be used in this instance if either the light or the Therma-Fuser diffuser cannot be relocated.

INSTALLATION INSTRUCTIONS

1. Inspect the carton for damage before opening. Notify carrier if external damage exists. Submit all claims for shipping damage to the carrier.
2. Move diffusers (in cartons) to installation area. Note unit identification.
3. Remove cardboard box and cardboard insert. Discard packing material.
4. If other than 4 way blow pattern is factory installed, note the "AIRFLOW" markings on the top of the diffuser and locate those sides in the proper direction.
5. Install in ceiling grid. Install T-bar support wire close to each corner of diffuser. Make sure that only wire suspended T-bars are used to support diffuser weight. (Adaptor frames are available for other than lay in ceilings.)
6. Connect and secure the supply duct to the collar. Flexible duct should NOT be formed in a centerline radius of less than 1½ times the duct diameter.
7. Do NOT reset the temperature set point on the TF-C, TF-CW and TF-HC models until the space is occupied. It is factory preset for average conditions (74°F/23°C).

Fig 1. Dimensions TF-C, TF-CW, TF-HC, TF-D and TF-RA

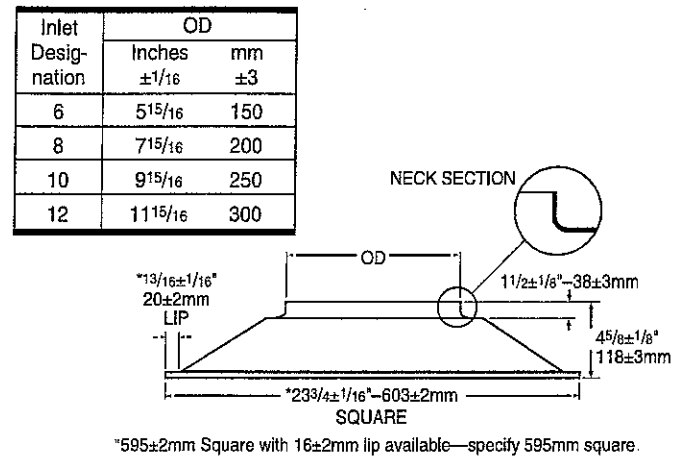

8 Balance the system. See *Balancing*.

9. After the air conditioning system is started and **after the space is occupied**, where necessary adjust the temperature set point on TF-C, TF-CW and TF-HC models to suit the occupant. See *Adjusting Temperature*.

OPERATING INSTRUCTIONS

Operating instructions for models TF-C, TF-CW and TF-HC are located on the back of the appearance panel.

OPENING THE APPEARANCE PANEL (TF-C, TF-CW, TF-HC, TF-D)

The appearance panel is attached with a latch clip on one side and hinges on the opposite side.

To open the appearance panel (on a Therma-Fuser diffuser installed in the ceiling):

1. Locate the side of the Therma-Fuser diffuser with the thermostat(s). Using two hands, one on each side of the latch clip bracket, place your fingers above the appearance panel and firmly pull down to disengage the clip. The appearance panel will rotate and hang down vertically on the hinges.

To close the appearance panel:

1. Rotate the panel upward.
2. Latch the panel by pushing the clip into the small square hole in the bracket.

To remove the appearance panel:

1. Open appearance panel as described above.
2. Rotate the appearance panel away from the latch clip bracket to force the hinge hooks open on the panel.
3. Slightly lift the panel to remove from the hinges.

To reattach the appearance panel:

1. Hang the appearance panel on the hinges.
2. Press the hinge hooks against the panel to close around the hinge brackets.
3. Close panel as describe above.

BALANCING (TF-C, TF-CW AND TF-HC)

VAV systems are balanced for design air volume at maximum air flow and systems using Therma-Fuser VAV diffusers are no exception. When all the Therma-Fuser diffusers are set for maximum air flow by fully opening them, the system is really a constant air volume system and is balanced as a constant volume system. Balancing dampers are best located at the takeoff before the runout to the Therma-Fuser diffuser.

- 1 Prepare system for balancing. (Make necessary checks for diversity, fan capacities, fan rotation, minimum outside air requirements, duct leaks and static pressure controller design setting. Set outside air control damper for minimum air and return air control damper for maximum air.)
- 2 Open Therma-Fuser diffusers
 - a. Open appearance panel
 - b. Unhook tension spring bracket adjacent to cooling thermostat. See Fig. 2.
 - c. If perimeter blades do not immediately drop to open position, turn the control plate slightly until they open.
 - d. Close appearance panel.

Note: If the Therma-Fuser diffuser is equipped with a R-Ring (Ceiling plenum relief ring) do not disconnect the spring. Use temporary balancing stops made of wood supplied with the diffuser to hold the blades open the proper distance for balancing. Thickness of the stop will depend on the size of the R-Ring used.

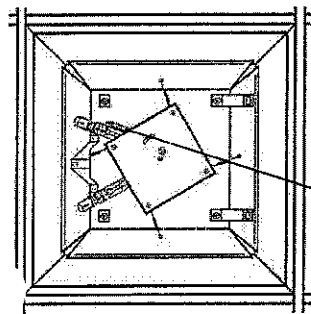

Fig. 2 Remove spring to drop blades open for balancing

- 3 Start fans, adjust system for 100% air flow and make system checks. (Measure static pressure across filters and coils and at sensor for static pressure controller. Measure supply, return and branch duct air flow.)
- 4 Place a direct reading diffuser balancing hood over the face of each Therma-Fuser diffuser and adjust damper at duct takeoff to obtain maximum design air volume.
- 5 Return Therma-Fuser diffusers to operating condition
 - a. Open appearance panel
 - b. Attach tension spring to bracket (removed in step 2b)
 - c. Close appearance panel

BALANCING (TF-D)

- 1 Measure the blade openings (See Fig. 3) and readjust where necessary by turning the adjusting screw in the center of each blade. Recommended initial blade openings are:

Inlet Description	Blade Opening
6	3/8" - 10mm
8	1/2" - 13mm
10	3/4" - 19mm
12	1-1/8" - 29mm

- 2 Adjust for proper air volume with the balancing damper at the duct takeoff. Each blade on the diffuser can also be separately adjusted. Recommended discharge velocity is 1200 fpm - 6m/sec.

Fig. 3 Measuring blade opening

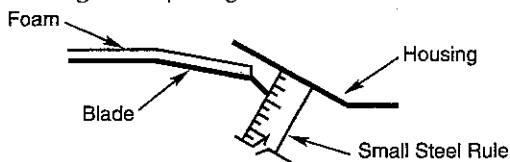

ADJUSTING TEMPERATURE

Room temperature set points are adjusted by screwing the thermostats in or out - in for cooler or out for warmer. Determine the set point by aligning the white indicator with the °F or °C numbers on the temperature scale.

The thermostats may be slightly harder to screw in or out when warm because the shaft is extended putting more pressure on the thermostat. If you are unable to turn the thermostat in this situation, cool the thermostat by holding an ice cube to the large end. The shaft will then contract and the thermostat will turn easily for adjustment.

Fig. 4 Room temperature set point adjustment

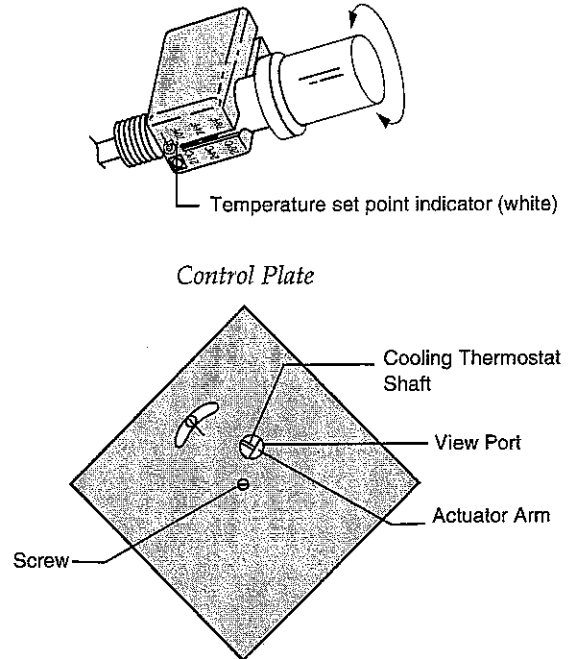

For proper operation make sure that the extension shaft on the cooling thermostat is in the actuator arm dimple. Check by sighting through the control plate viewport. If the shaft is not in the dimple, cool the thermostat by holding ice to the large end until the shaft retracts and move the shaft into the dimple.

RECOMMENDED ADJUSTMENTS FOR VARIOUS CONDITIONS

	Room Temp.	Blade Position	Recommended Action
Cooling Mode	Too Cold	Open	Adjust cooling for higher room temperature set point. (Screw cooling thermostat out.)
		Closed	Therma-Fuser diffuser is correct. Check if cooling is still required, and if not, turn cooling unit off.
TF-C TF-CW TF-HC	Too Warm	Open	Therma-Fuser diffuser is correct. Check for lack of air or for too warm air temperature.
		Closed	Adjust cooling thermostat for lower room temperature set point. (Screw cooling thermostat in.)
Heating Mode	Too Cold	Open	Therma-Fuser diffuser is correct. Check for lack of air or too low air temperature.
		Closed	Adjust heating thermostat for higher room temperature set point. (Screw heating thermostat out.)
TF-HC	Too Warm	Open	Adjust heating thermostat for lower room temperature set point. (Screw heating thermostat in.)
		Closed	Therma-Fuser diffuser is correct. Check if heating is still required, and if not, turn it off.
Too Noisy TF-C TF-CW TF-HC TF-D	Any	Any	Reduce static pressure. Recommended static pressure is .05 to .25 wg / 10 to 60 Pa at the inlet of the diffuser. If lower noise level does not result from lower static pressure, check for and correct noise generating restrictions in the duct up stream such as large pressure drops over dampers, heaters, etc.

DAMPER BLADE ADJUSTMENT (TF-C, TF-CW, AND TF-HC)

If one of the blades does not track uniformly with the others make a simple field adjustment to the spoke wire which connects the blade to the control plate. A pair of needle nose pliers or similar tool is all that is required. If the blade does not open as rapidly as the other blades, insert the pliers *inside* of the closed loop in the spoke wire and *slightly expand* the loop. If the blade opens more rapidly than the others, place the pliers *outside* of the closed loop and *slightly compress* the loop. No other adjustment is required.

BLOW PATTERNS (TF-C, TF-CW, AND TF-HC)

A major selling feature of the TF-C, TF-CW and TF-HC diffusers is the ability to easily add or remove blow patterns in the field. This is done by blocking the air off behind the blades on the appropriate sides.

DO NOT:

- Disconnect the spokes.
- Tape, screw or otherwise lock the blade closed. This unbalances the loads on the center bearings.
- Block the four venturi nozzles.

DO block air flow behind the blades or between the standoffs (Standoffs are the supports between the housing and the diffusion plate.) Ways to do this are:

1. Factory installed directional baffles. These are strips of metal wrapped around the standoffs to block one, two or three sides. These can be removed in the field after first removing the diffusion plate assembly.
2. Field installed directional baffles. These are trapezoid pieces of metal that are laid horizontally on top of the corner supports. Dimensions are as shown in Fig 5. Directional baffles can be made locally or purchased from Acutherm.
3. 1-5/8" diameter x 10' long (Armaflex) for split system refrigeration lines. Insert between the housing and the diffusion plate/blade assembly and wedge between the standoffs (See Fig. 6). Not supplied by Acutherm but easily available in the field.

The rule for blocking the appropriate side is: **Always block the thermostat side.** (See Fig 7 for examples.)

Fig 5 Field installed baffle

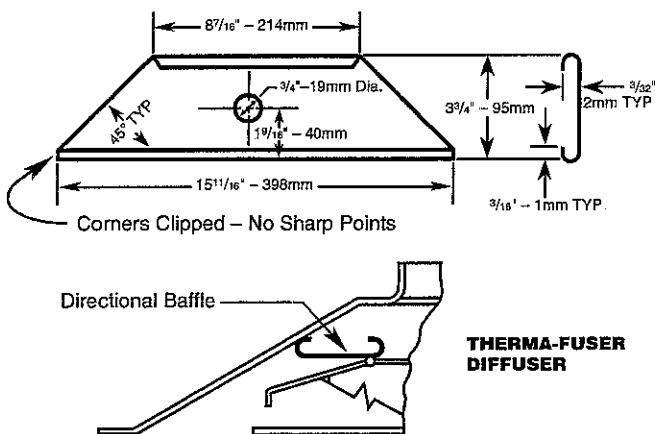

Fig. 6 Foam directional baffle

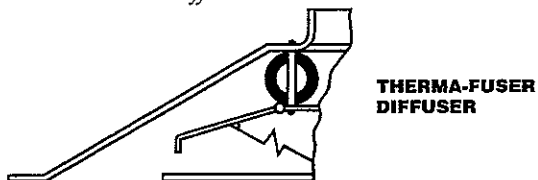
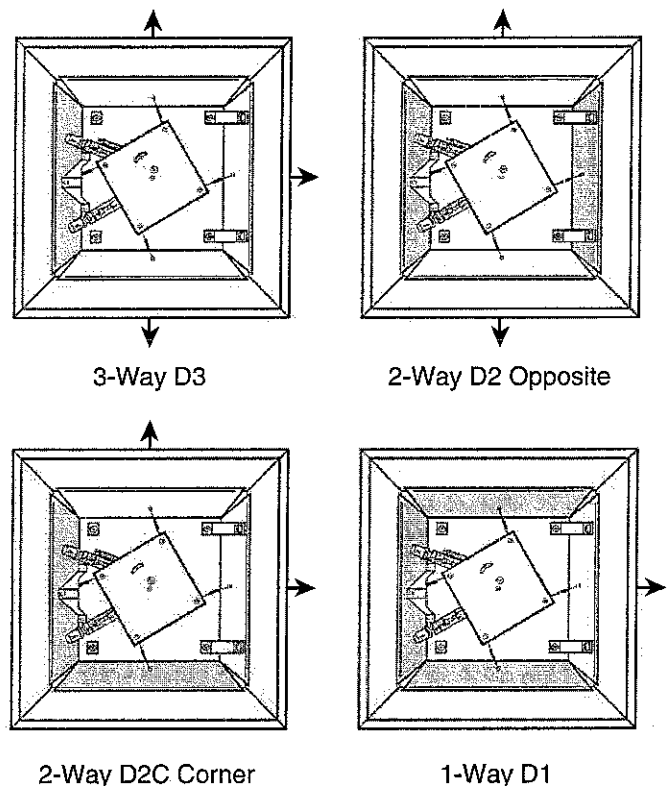

Fig 7 Blow Patterns



Note: Some earlier TF-C and TF-CW models have one induction slot by the thermostat instead of four venturi nozzles. The rule for blocking the appropriate side for this version is: **Never block the thermostat side.**

When blocking for direction, the air volume for a given static pressure is reduced from max. air volume listed in the performance guide by:

Blow Patterns	Reduction
3 way	.78
2 way	.56
1 way	.34

MAINTENANCE

The moving parts of the Therma-Fuser diffuser have no maintenance or lubrication requirements. Although all Therma-Fuser diffusers are individually inspected and checked before shipment (note the initials of the final assembler/inspector on the inspection tag) it is possible that misadjustment may occur. The following are guidelines for checking and adjustment.

Thermostat Check (TF-C, TF-CW- TF-HC)

1. Room sensing thermostat

Heat room thermostat with a hair dryer. Control plate should move clockwise. Cool room thermostat with ice or component cooler spray. Control plate should move counter clockwise.

A. For TF-CW and TF-HC, the thermostat in the neck should be cooled with ice or spray before checking the cooling room thermostat.

B. For TF-HC, the thermostat in the neck should be heated with a hair dryer before checking the heating room thermostat.

2. Neck thermostat (TF-CW warm-up thermostat and TF-HC change over thermostat.) The neck thermostat is factory set and requires no adjustment. Breaking the red or blue Loctite seal and changing the setting will cause the Therma-Fuser diffuser to function incorrectly. Warm neck thermostat with hair dryer. Control plate should move counter clockwise. Cool neck thermostat with ice or spray. Control plate should move clockwise.

TROUBLE SHOOTING (TF-C, TF-CW AND TF-HC)

Trouble shooting Therma-Fuser diffusers requires looking at the systems as a whole. Before examining the Therma-Fuser diffuser for failure it is worth the time to be sure the system is functioning properly and that something has not been overlooked. Before calling Acutherm, please complete the data log for all Therma-Fuser diffusers to be evaluated.

SYSTEM CHECK

The system should be:

- 1 Delivering 50°- 68°F/10° - 20°C supply air when in the cooling mode
- 2 Delivering 80°-120°F/26.5° - 49°C supply air when in the heating mode (TF-CW and TF-HC).
- 3 Maintaining static pressure at the inlet to each Therma-Fuser diffuser between .05 and .25"wg/12 Pa and 62 Pa
- 4 Maintaining continuous fan operation during occupied hours.

THERMA-FUSER DIFFUSER CHECK

Once the above checks have been completed examine and record the following (Conditions may vary over time; several measurements at different times may be required):

- 5 Room temperature 4ft/1.2m above the floor directly under the Therma-Fuser diffuser
- 6 Supply air temperature at the Therma-Fuser diffuser
- 7 Static pressure at the inlet of the Therma-Fuser diffuser
- 8 Blade opening from the edge of the blade measured perpendicular to the housing

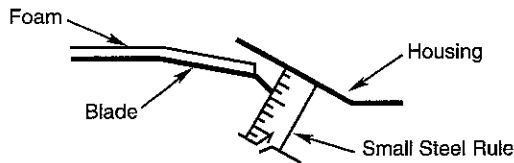

- 9 Control plate position (clockwise or counter clockwise from center).

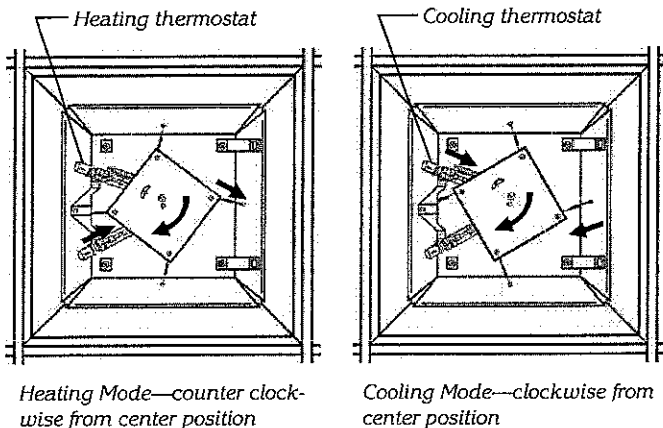

- 10 Cooling and heating setpoints

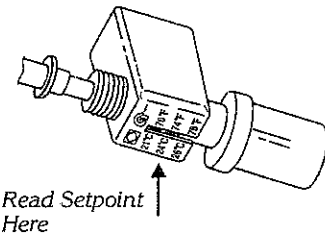

- 11 Thermostat extension

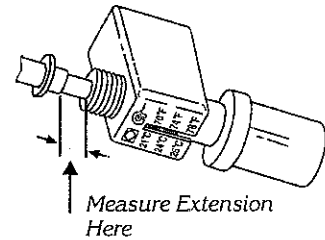

12. Is the Therma-Fuser diffuser located within 2ft/600mm of a vertical protrusion such as a wall or dropped beam which could disturb induction air flow?

DATA LOG

Location	Date	Time	Room Temp	S.A. Temp	Duct S.P.	Blade Opening	Control Disc Position	Set Points		Extension	
								Heating	Cooling	Heating	Cooling

TEN YEAR WARRANTY

Acutherm warrants that its Therma-Fuser diffusers, exclusive of any options and accessories (whether factory or field installed) shall be free from defects in material or workmanship for a period of ten (10) years from the date of shipment and agrees to repair or replace, at its option, any parts that fail during said ten (10) year period due to any such defects which would not have occurred had reasonable care been taken, provided that such parts have been inspected by Acutherm and found defective and provided the diffusers have been given normal and proper usage and all parts and controls remain unaltered. Acutherm makes NO WARRANTY OF MERCHANTABILITY OF PRODUCTS OR OF THEIR FITNESS FOR ANY PURPOSE OR ANY OTHER EXPRESS OR IMPLIED WARRANTY WHICH EXTENDES BEYOND THE LIMITED WARRANTY ABOVE. ACUTHERM'S LIABILITY FOR ANY AND ALL LOSSES AND DAMAGES RESULTING FROM DEFECTS SHALL IN NO EVENT EXCEED THE COST OF REPAIR OR REPLACEMENT OF PARTS FOUND DEFECTIVE UPON EXAMINATION BY ACUTHERM. IN NO EVENT SHALL ACUTHERM BE LIABLE FOR INCIDENTAL, INDIRECT OR CONSEQUENTIAL DAMAGES OR DAMAGES FOR INJURY TO PERSONS OR PROPERTY. Acutherm shall not be responsible for freight to or from its plant in connection with the inspection, repair or replacement of parts under the terms of this limited warranty nor for cost of removal or installation.



The Individual
Temperature Control People
1766 Sabre Street
Hayward, CA 94545
Tel: (510) 785-0510
Fax: (510) 785-2517
http://www.acutherm.com
e-mail: info@acutherm.com