

GENERAL NOTES:

- ALL CONSTRUCTION SHALL CONFORM TO THE LATEST CITY OF REDWOOD CITY STANDARD DETAILS AND SPECIFICATIONS.
- BENCHMARK:
PLATE OF MONUMENT AT THE INTERSECTION OF GRAND STREET AND D STREET.
ELEVATION = 87.206 NGVD29 CITY DATUM
- THE ENGINEER ASSUMES NO RESPONSIBILITY BEYOND THE ADEQUACY OF HIS DESIGN CONTAINED HEREIN.
- ANY DEVIATIONS OR CHANGES IN THESE PLANS WITHOUT OFFICIAL APPROVAL OF THE DESIGN ENGINEER SHALL ABSOLVE THE DESIGN ENGINEER OF ANY AND ALL RESPONSIBILITY OF SAID DEVIATION OR CHANGE.
- IT SHALL BE THE CONTRACTOR'S RESPONSIBILITY TO NOTIFY THE ENGINEER OF ANY DIFFERENCES IN LOCATIONS OF EXISTING UTILITIES SHOWN, OR ANY CONFLICTS WITH THE DESIGN, BEFORE CONTINUING WITH WORK IN THAT AREA.
- DAVID EVANS & ASSOCIATES, INC. SHALL BE NOTIFIED 48 HOURS IN ADVANCE OF WHEN FIELD STAKING IS TO BE REQUIRED.
- THE TERM "CONTRACTOR" USED IN THE FOLLOWING NOTES REFERS TO ALL GENERAL CONTRACTORS AND SUBCONTRACTORS RETAINED BY THE OWNER TO PERFORM CONSTRUCTION SERVICES ON THIS PROJECT.
- CONSTRUCTION CONTRACTOR AGREES THAT IN ACCORDANCE WITH GENERALLY ACCEPTED CONSTRUCTION PRACTICES, CONSTRUCTION CONTRACTOR WILL BE REQUIRED TO ASSUME SOLE AND COMPLETE RESPONSIBILITY FOR JOB SITE CONDITIONS DURING THE COURSE OF CONSTRUCTION OF THE PROJECT, INCLUDING SAFETY OF ALL PERSONS AND PROPERTY; THAT THIS REQUIREMENT SHALL BE MADE TO APPLY CONTINUOUSLY AND NOT BE LIMITED TO NORMAL WORKING HOURS, AND CONSTRUCTION CONTRACTOR FURTHER AGREES TO DEFEND, INDEMNIFY AND HOLD DESIGN PROFESSIONAL HARMLESS FROM ANY AND ALL LIABILITY, REAL OR ALLEGED, IN CONNECTION WITH THE PERFORMANCE OF WORK ON THIS PROJECT, EXCEPTING LIABILITY ARISING FROM THE SOLE NEGLIGENCE OF DESIGN PROFESSIONAL.
- THE CONTRACTOR SHALL NOTIFY THE DEPARTMENT OF STATE ARCHITECTURE (DSA) 24 HOURS PRIOR TO REQUIRED INSPECTION (916) 445-8100 THE CONTRACTOR SHALL SUBMIT CUT SHEETS FOR SANITARY SEWERS, STORM DRAINS AND CURB AND GUTTER 24 HOURS PRIOR TO CONSTRUCTION.
- CONTRACTOR SHALL KEEP EXISTING STREETS FREE FROM DIRT AND DEBRIS DURING ALL PHASES OF CONSTRUCTION.
- COMPACTION TESTS WILL BE PERFORMED ON ALL TRENCHES AND STREET WORK TO VERIFY THAT COMPACTION CONFORMS TO STANDARDS. THE TESTING WILL BE PERFORMED BY THE CONTRACTOR.
- EXCAVATIONS SHALL BE ADEQUATELY SHORED, BRACED AND SHEETED SO THAT THE EARTH WILL NOT SLIDE OR SETTLE AND SO THAT ALL EXISTING IMPROVEMENTS OF ANY KIND WILL BE FULLY PROTECTED FROM DAMAGE. ANY DAMAGE RESULTING FROM LACK OF ADEQUATE SHORING, BRACING AND SHEETING, SHALL BE THE RESPONSIBILITY OF THE CONTRACTOR AND HE SHALL EFFECT NECESSARY REPAIRS OR RECONSTRUCTION AT HIS OWN EXPENSE. WHERE THE EXCAVATION FOR A CONDUIT TRENCH, STRUCTURE AND/OR BORING OR JACKING PIT IS FIVE FEET OR MORE IN DEPTH THE CONTRACTOR SHALL CONFORM TO THE APPLICABLE CONSTRUCTION SAFETY ORDERS OF THE DIVISION OF INDUSTRIAL SAFETY OF THE STATE OF CALIFORNIA. THE CONTRACTOR SHALL ALWAYS COMPLY WITH OSHA REQUIREMENTS.
- CONTRACTOR SHALL COMPLY WITH THE RULES AND REGULATIONS OF THE STATE CONSTRUCTION SAFETY ORDER.
- CONTRACTOR SHALL POST EMERGENCY TELEPHONE NUMBERS FOR PUBLIC WORKS, AMBULANCE, POLICE AND FIRE DEPARTMENTS.
- THE CONTRACTOR'S ATTENTION IS DIRECTED TO THE REQUIREMENTS OF THE DIVISION OF INDUSTRIAL SAFETY PERTAINING TO "CONFINED SPACES". ANY MANHOLE, CULVERT, DROP INLET OR TRENCH, THAT IS NOT READILY VENTILATED, MAY BE CONSIDERED A "CONFINED SPACE".
- ALL TRENCHES OVER FIVE FEET IN DEPTH SHALL BE SHORED IN ACCORDANCE WITH CAL-OSHA "CONSTRUCTION SAFETY ORDERS" CURRENT EDITION. CONTRACTOR MUST HAVE VALID TRENCH SHORING PERMIT ISSUED BY CAL-OSHA.
- THE CONTRACTOR SHALL PROVIDE ALL LIGHTS, SIGNS, BARRICADES, FLAGMEN, OR OTHER DEVICES NECESSARY TO PROVIDE FOR PUBLIC SAFETY AND TO MAINTAIN TRAFFIC CONTROL AT ALL TIMES.
- THE CONTRACTOR SHALL PROVIDE FOR INGRESS AND EGRESS TO PRIVATE PROPERTY ADJACENT TO THE WORK AREA THROUGHOUT THE PERIOD OF CONSTRUCTION.
- THE CONTRACTOR SHALL COORDINATE ALL NECESSARY UTILITY INSTALLATIONS AND RELOCATIONS WITH THE APPROPRIATE UTILITY COMPANIES.
- THE CONTRACTOR SHALL NOT DISTURB OR DESTROY ANY PERMANENT SURVEY POINTS WITHOUT THE CONSENT OF THE INSPECTOR. ANY PERMANENT MONUMENTS OR POINTS DESTROYED SHALL BE REPLACED BY A LICENSED ENGINEER OR SURVEYOR AT THE CONTRACTOR'S EXPENSE.
- ENCROACHMENT PERMITS REQUIRED FOR WORK WITHIN EXISTING PUBLIC RIGHTS-OF-WAY SHALL BE OBTAINED BY THE CONTRACTOR.
- OBSTRUCTIONS INDICATED ARE FOR INFORMATION ONLY. IT IS THE CONTRACTOR'S RESPONSIBILITY TO VERIFY THE LOCATION AND DEPTH WITH THE APPROPRIATE AGENCIES. THE CONTRACTOR SHALL NOTIFY USA (UNDERGROUND SERVICE ALERT) FOR THE UTILITY LOCATIONS 48 HOURS PRIOR TO ANY CONSTRUCTION (800-227-2600). NEITHER THE OWNER NOR THE ENGINEER ASSUMES RESPONSIBILITY THAT THE OBSTRUCTIONS INDICATED WILL BE THE OBSTRUCTIONS ENCOUNTERED. THE USA AUTHORIZATION NUMBER SHALL BE KEPT AT THE JOB SITE.
- WHERE UNSTABLE OR UNSUITABLE MATERIALS ARE ENCOUNTERED DURING SUBGRADE PREPARATION, THE AREA IN QUESTION SHALL BE OVER EXCAVATED AND REPLACED BY SELECT BACKFILL MATERIAL AS DIRECTED IN THE FIELD BY THE INSPECTOR.
- WHERE ABANDONED UNDERGROUND STRUCTURES ARE ENCOUNTERED IN THE STREET AREAS, REMOVE TO SUFFICIENT DEPTH TO ALLOW UNDERGROUND LINES TO CROSS, BACKFILL AND COMPACT DURING ROUGH GRADING. THE INSPECTOR MAY REQUIRE FURTHER WORK TO BE DONE IF VISUAL INSPECTION INDICATES DURING CONSTRUCTION.
- ALL WORK ADJACENT TO EXISTING PAVEMENT SECTION SHALL BUTT UP TO FULL EXISTING SECTION. WHERE FULL SECTION IS NOT ENCOUNTERED, CONTINUE REMOVAL OF ADDITIONAL PAVEMENT UNTIL A FULL SECTION IS FOUND.
- ALL EXISTING ELEVATIONS SHOWN ARE AS MEASURED IN THE FIELD UNLESS OTHERWISE NOTED.
- THE ENGINEER ASSUMES NO RESPONSIBILITY FOR FINAL GRADE OF CONCRETE UNLESS FORMS ARE CHECKED BY THE ENGINEER PRIOR TO POURING.
- SHOULD IT APPEAR THAT THE WORK TO BE DONE, OR ANY MATTER RELATIVE THERETO, IS NOT SUFFICIENTLY DETAILED OR EXPLAINED ON THESE PLANS, THE CONTRACTOR SHALL CONTACT DAVID EVANS AND ASSOCIATES, INC. AT (925) 867-3380 FOR SUCH FURTHER EXPLANATIONS AS MAY BE NECESSARY.
- ALL REVISIONS TO THIS PLAN MUST BE REVIEWED BY THE DSA PRIOR TO CONSTRUCTION AND SHALL BE ACCURATELY SHOWN ON REVISED PLANS STAMPED AND DISTRIBUTED BY THE DSA.
- ASBESTOS CEMENT PIPE (ACP) SHALL NOT BE USED IN THE CONSTRUCTION OF ANY STORM DRAINAGE FACILITIES.
- EXISTING CURBS AND SIDEWALKS WITHIN THE PROJECT LIMITS THAT ARE DAMAGED OR DISPLACED, EVEN THOUGH THEY WERE NOT TO BE REMOVED, SHALL BE REPAIRED OR REPLACED EVEN IF DAMAGE OR DISPLACEMENT OCCURRED PRIOR TO ANY WORK PERFORMED BY THE CONTRACTOR.
- IF PAVING AND STORM DRAIN IMPROVEMENTS ARE NOT COMPLETED BY OCTOBER 15, TEMPORARY SILT AND DRAINAGE CONTROL FACILITIES SHALL BE INSTALLED TO CONTROL AND CONTAIN EROSION-CAUSED SILT DEPOSITS AND TO PROVIDE FOR THE SAFE DISCHARGE OF STORM WATERS INTO EXISTING STORM WATER FACILITIES. DESIGN OF THESE FACILITIES MUST BE APPROVED BY THE DSA.
- CONTRACTOR SHALL SCHEDULE A PRECONSTRUCTION CONFERENCE WITH THE DSA PRIOR TO COMMENCEMENT OF ANY WORK.
- ALL MANHOLES, VALVES AND MONUMENT FRAMES SHALL BE SET TO FINISH GRADE AFTER PAVING.
- ALL SEWER AND STORM DRAIN CONSTRUCTION SHALL PROCEED FROM THE DOWNSTREAM CONNECTION TO THE UPSTREAM TERMINUS.
- THE CONTRACTOR SHALL PROVIDE ADEQUATE COVER FOR THE PROTECTION OF ALL PROPOSED AND EXISTING UTILITIES DURING THE CONSTRUCTION OF THIS PROJECT.
- SANITARY SEWERS:
 - ALL SANITARY SEWER CONSTRUCTION WILL BE SUBJECT TO FINAL T.V. INSPECTION AND APPROVAL BY THE DSA. INSPECTION WILL ONLY BE MADE AFTER SEWER MAINS AND LATERALS HAVE PASSED THE LOW PRESSURE AIR TEST, THE MAIN LINES HAVE BEEN CLEANED WITH A "WAYNE BALL", PVC LINES HAVE PASSED THE 95% MANDREL TEST, AND MANHOLES HAVE BEEN RAISED TO GRADE AND MORTARED. DURING BALLING OF SEWER LINES, THE MANHOLE AT THE LOW END OF THE NEW LINE SHALL BE PLUGGED AND INCOMING WATER PUMPED TO A DRAIN POINT APPROVED BY THE DSA. BEFORE THE PLUG CAN BE REMOVED, ALL SAND, SILT, GRAVEL AND OTHER FOREIGN MATERIAL, SHALL BE COMPLETELY REMOVED FROM THE MANHOLE.
 - NEW SEWERS SHALL NOT BE CONNECTED INTO EXISTING MAINS WITHOUT THE DSA'S APPROVAL.
- WATER SYSTEM:
 - ALL WATER LINES SHALL HAVE A MINIMUM COVER OF 36".
 - WATER MAINS AND APPURTENANCES SHALL BE INSTALLED AS A PART OF THIS SUBDIVISION IN ACCORDANCE WITH CITY OF REDWOOD CITY STANDARD SPECIFICATIONS.
 - ALL CONSTRUCTION ON THE WATER SUPPLY SYSTEM WILL BE SUBJECT TO FINAL INSPECTION AND APPROVAL BY THE DSA. INSPECTION WILL ONLY BE MADE AT SUCH TIME AS ALL WORK ON THE WATER SUPPLY HAS BEEN COMPLETED.
 - VALVE EXTENSIONS ARE REQUIRED ON ALL VALVES WHERE WATERLINE COVER EXCEEDS THREE FEET.
- TRAFFIC CONTROL:
 - PRIOR TO BEGINNING ANY WORK ON EXISTING STREETS, ADVANCE WARNING SIGNS (C18 AND C13) SHALL BE INSTALLED.
 - TWO-WAY TRAFFIC (12' MINIMUM LANES) SHALL BE MAINTAINED AT ALL TIMES UNLESS OTHERWISE APPROVED BY THE DSA.
 - TRAFFIC CONTROL SHALL BE PROVIDED IN ACCORDANCE WITH CALTRANS "MANUAL OF TRAFFIC CONTROLS FOR CONSTRUCTION AND MAINTENANCE WORK ZONES" CURRENT EDITION. FAILURE TO COMPLY MAY RESULT IN IMMEDIATE STOPPAGE OF WORK UNTIL THE PROPER TRAFFIC CONTROL IS IN ORDER.
- THE CONTRACTOR SHALL HAVE A JOB SUPERINTENDENT OR A DESIGNATED RESPONSIBLE REPRESENTATIVE ON THE JOB SITE ANYTIME WORK IS IN PROGRESS DURING THE CONSTRUCTION OF THE PROJECT. THE CONTRACTOR SHALL ADVISE THE DSA WHOM THE DESIGNEE IS IN WRITING. THE NOTICE SHALL INCLUDE AN EMERGENCY NOTIFICATION PHONE NUMBER. THE DSA SHALL BE ADVISED IN WRITING IF THERE IS TO BE A CHANGE IN JOB-SITE REPRESENTATIVE.
- IN ORDER TO EXPEDITE THE WORK IN CONJUNCTION WITH THE IMPROVEMENTS AND TO AVOID IRREPARABLE DAMAGE TO, OR DETERIORATION OF QUALITY OF, ANY PORTION OF THE PUBLIC WORKS IMPROVEMENTS, IT SHALL BE THE DUTY AND RESPONSIBILITY OF THE CONTRACTOR TO SCHEDULE THE MAJOR ITEMS IN THE FOLLOWING ORDER:
 - STREET EXCAVATION AND ROUGH GRADING.
 - STORM AND SANITARY SEWERS.
 - UNDERGROUND GAS, ELECTRIC, TELEPHONE, T.V., WATER FACILITIES AND THEIR SERVICES.
 - CURB, GUTTER AND SIDEWALK.
 - STREET SUB-BASE (IF REQUIRED).
 - BASE ROCK.
 - PAVING.
- CONSTRUCTION OPERATIONS - WASTEWATER GENERATED DURING CONSTRUCTION SHALL NOT BE DISCHARGED TO THE STORM DRAIN SYSTEM. THIS INCLUDES WASTE FROM PAINTING, SAWCUTTING, CONCRETE WORK, ETC. THE CONTRACTOR SHALL MAKE ARRANGEMENTS TO ELIMINATE DISCHARGES TO THE STORM DRAIN SYSTEM AND, IF NECESSARY, PROVIDE AN AREA FOR ON-SITE WASHING ACTIVITIES DURING CONSTRUCTION. MATERIALS WHICH COULD CONTAMINATE STORM RUNOFF SHALL BE STORED IN AREAS WHICH ARE DESIGNED TO PREVENT EXPOSURE TO RAINFALL AND TO NOT ALLOW STORM WATER TO RUN ONTO THE AREA.
- PAVEMENT CLEANING - FLUSHING OF STREETS/PARKING LOTS TO REMOVE DIRT AND CONSTRUCTION DEBRIS IS PROHIBITED UNLESS PROPER SEDIMENT CONTROLS ARE USED. PREFERABLY, AREAS REQUIRING CLEANING SHOULD BE SWEEPED.
- EROSION AND SEDIMENTATION CONTROL MEASURES SHALL BE IMPLEMENTED BY OCTOBER 15TH.
- DURING GRADING OPERATIONS, THE CONTRACTOR SHALL IMPLEMENT DUST CONTROL MEASURES BOTH ON-SITE AND ON THE HAUL ROUTE. STREETS SHALL BE SWEEPED A MINIMUM OF TWO TIMES A DAY OR AS REQUIRED BY THE DSA. CONTRACTOR SHALL PROVIDE DUST CONTROL AT ALL TIMES.
- ALL GRADING SHALL BE IN ACCORDANCE WITH THE STORM WATER POLLUTION PREVENTION PLAN.

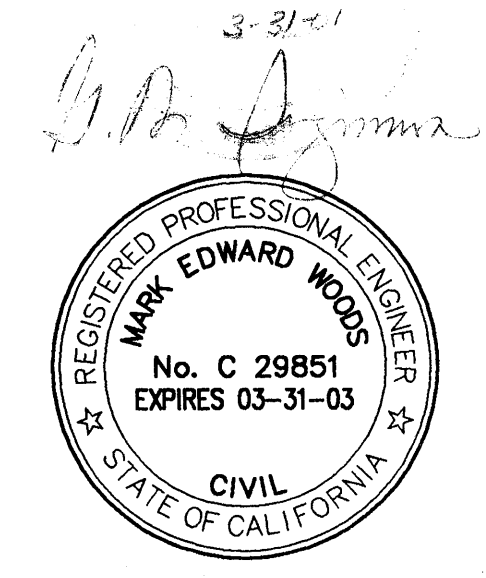
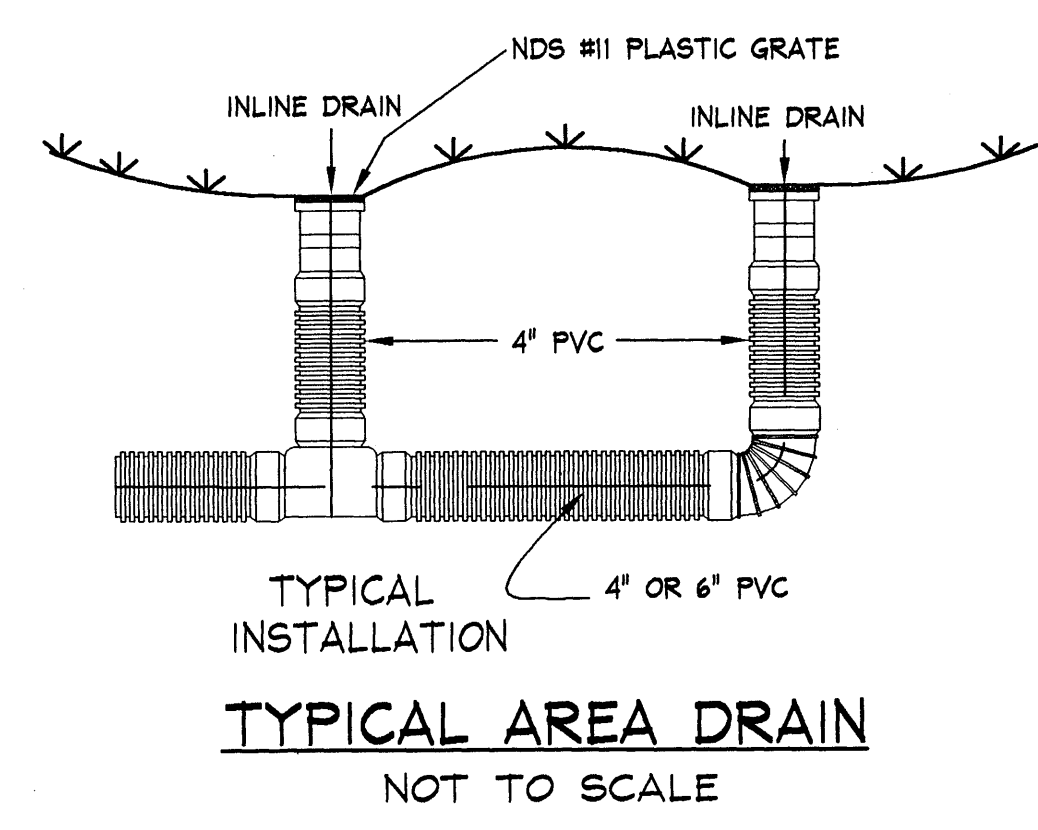
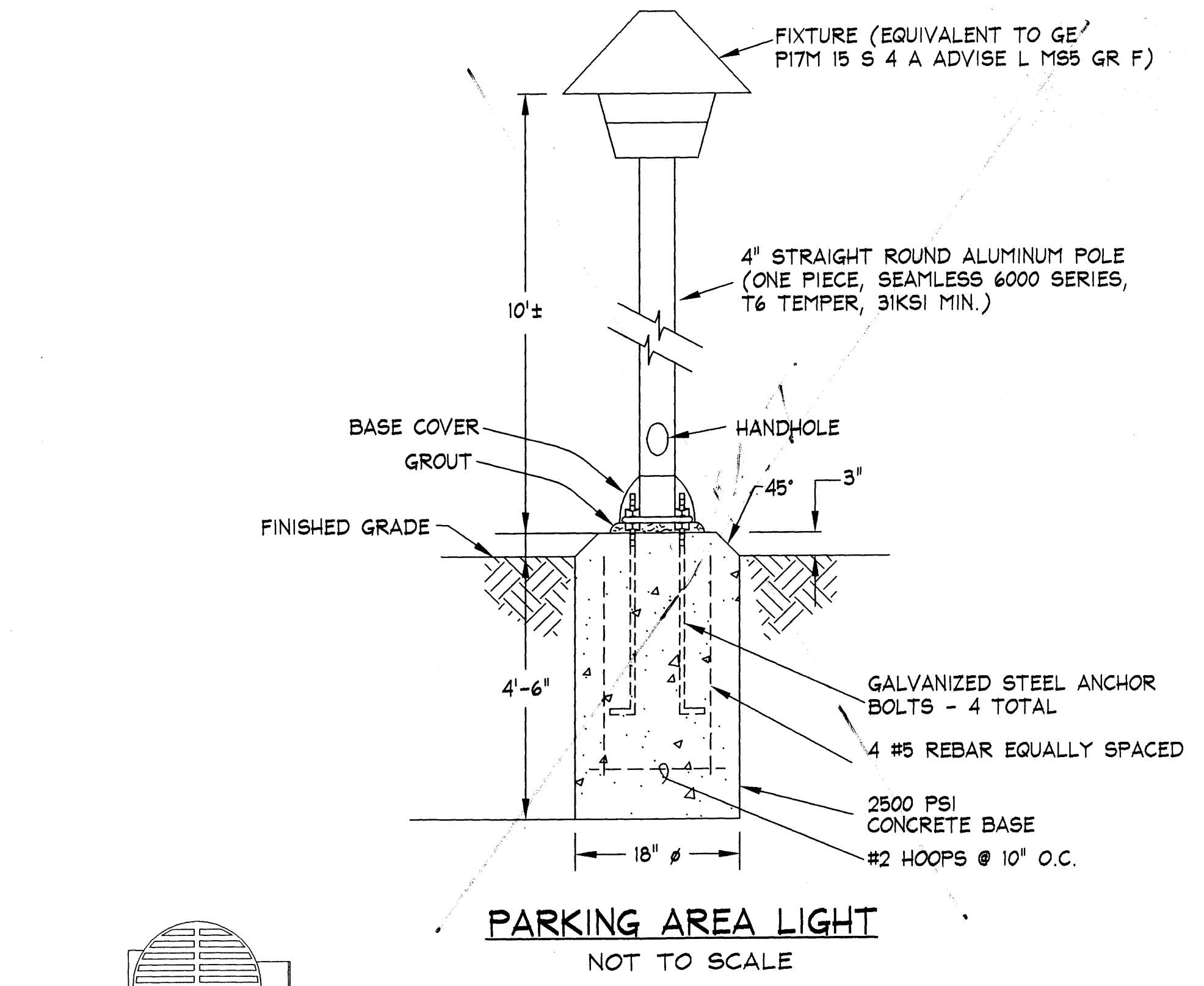
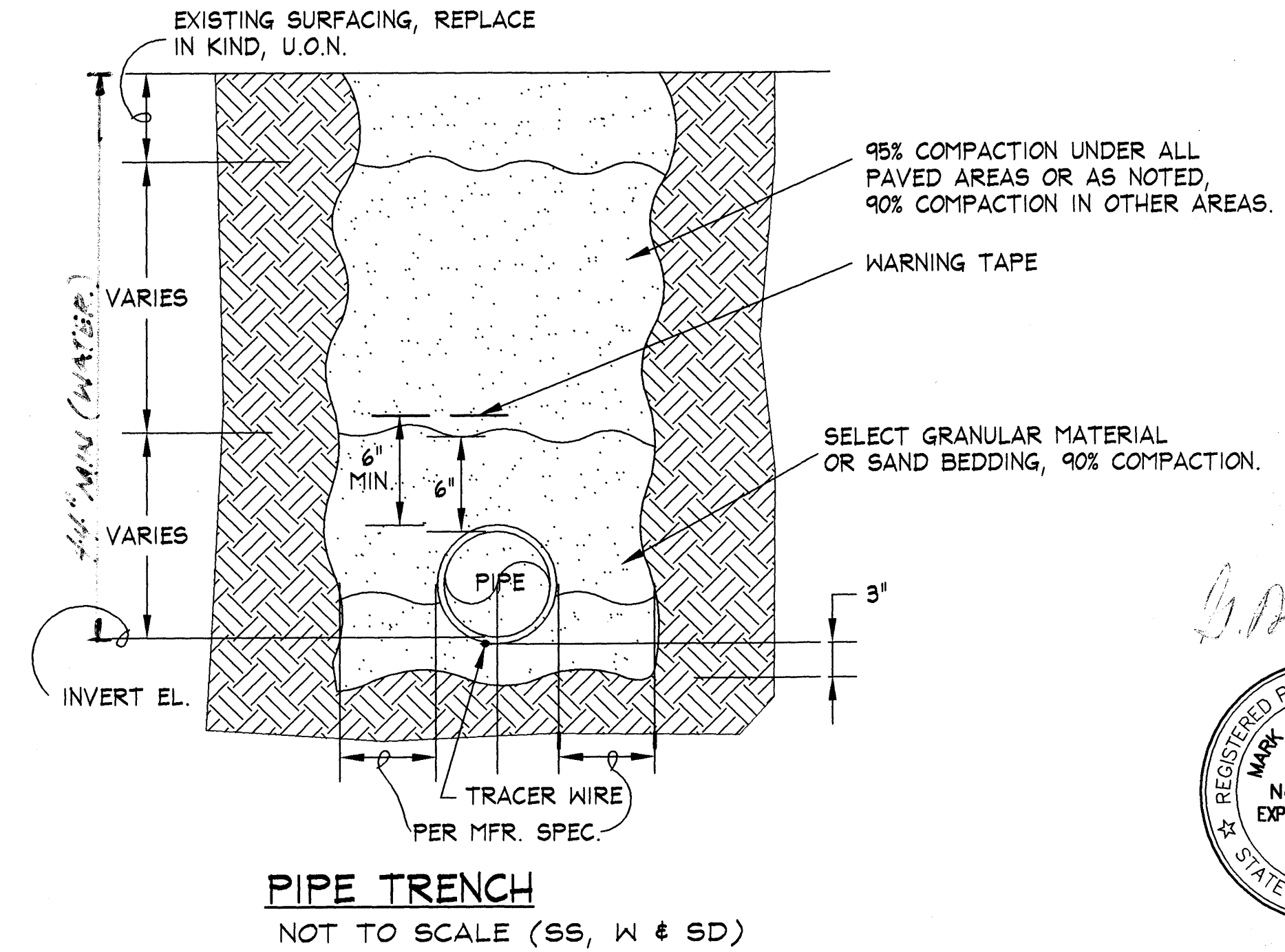
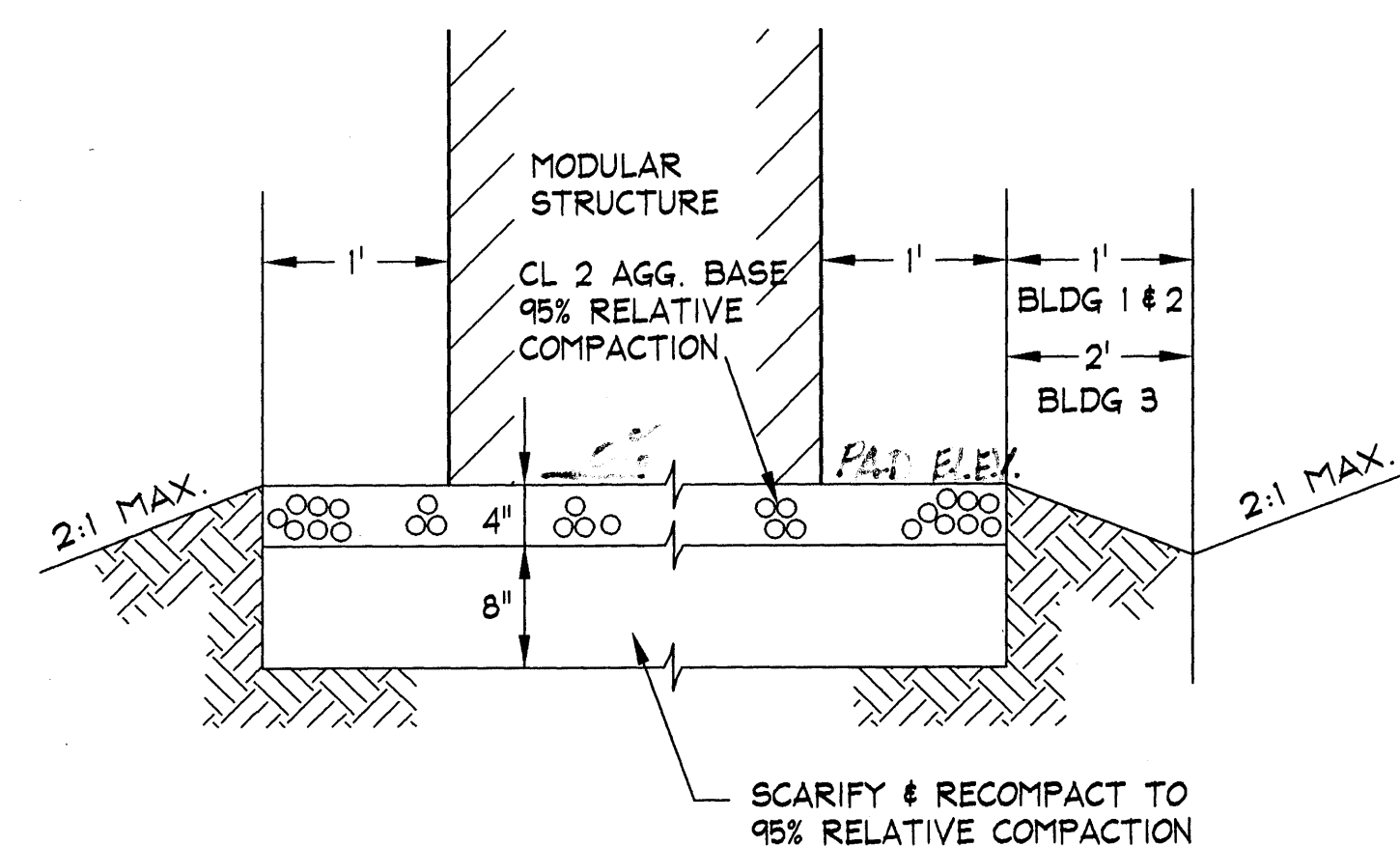
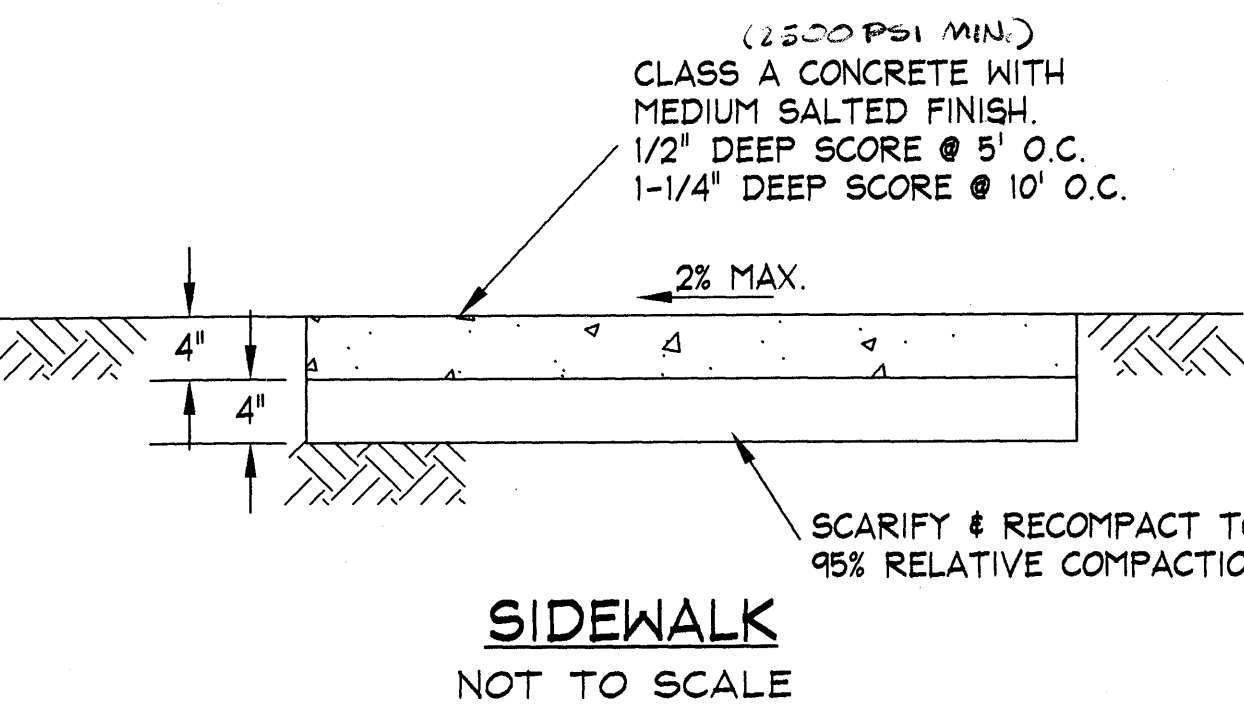
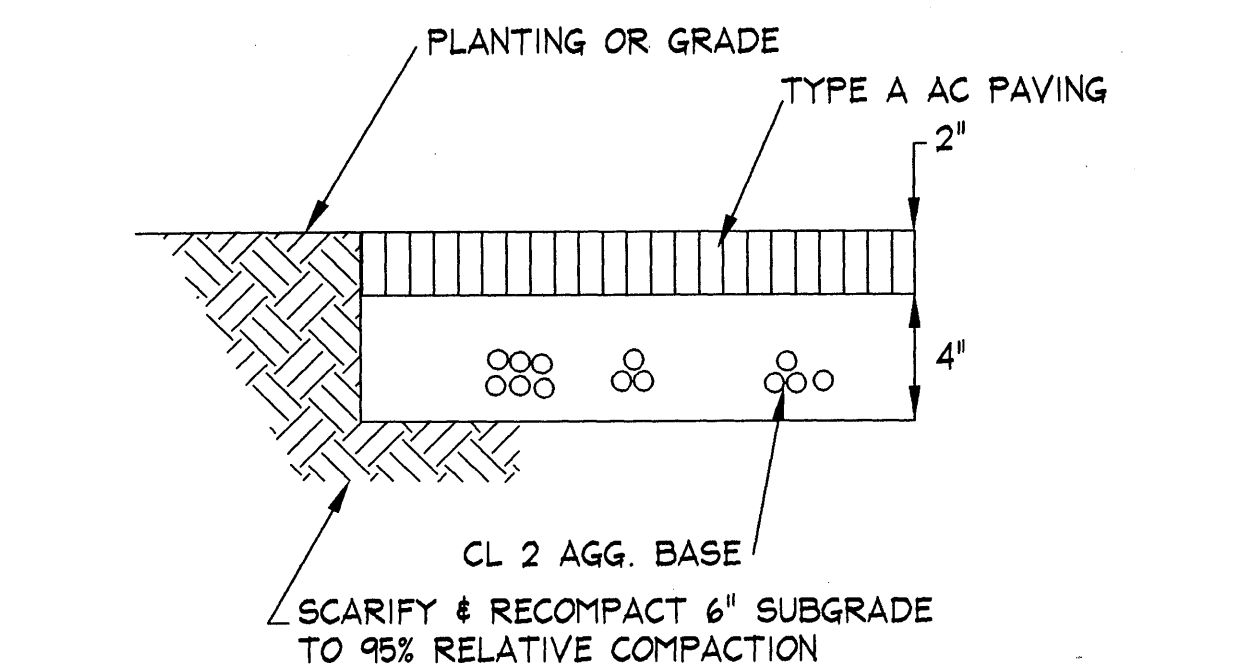

CITY APPROVAL

PREPARED UNDER THE SUPERVISION OF

SCALE: AS SHOWN

DATE: 12/15/00

DRAWN BY: LTM

ENGINEER: MEW

CHECKED BY:

PG.

NOI BY DATE

DAVID EVANS AND ASSOCIATES, INC.
5000 EXECUTIVE PARKWAY,
SUITE 125
SAN RAMON, CALIFORNIA
94583

INC.

TEL: (925) 867-3380 FAX: (925) 867-3388

SAN MATEO COUNTY COMMUNITY COLLEGE DISTRICT

NOTES & DETAILS

CALIFORNIA

REDWOOD CITY

CANADA COLLEGE

SHEET NO. 2 OF 8 SHEETS

JOB No. SMCC0000-0003