

- GENERAL NOTES
- This sheet is part of a set and is not to be used alone.
 - This sheet is not to be used for construction unless the architect's stamp and signature appear on the drawings and the status box indicates drawings have been released for construction.
 - These plans and prints thereof, as instruments of service, are owned by the architect and are for use on this project only. Reproduction and/or distribution without the prior written consent of the architect is forbidden.
 - Copyright Burton Clifford Associates, 2008

REVISIONS	DATE
1. ADJUSTMENT 1	08/18/09
2. SEE ATTACHMENT 9	
3. SEE ATTACHMENT 9	
4. SEE ATTACHMENT 9	
5. SEE ATTACHMENT 9	
6. SEE ATTACHMENT 9	
7. SEE ATTACHMENT 9	
8. SEE ATTACHMENT 9	
9. SEE ATTACHMENT 9	
10. SEE ATTACHMENT 9	
11. SEE ATTACHMENT 9	
12. SEE ATTACHMENT 9	
13. SEE ATTACHMENT 9	
14. SEE ATTACHMENT 9	
15. SEE ATTACHMENT 9	
16. SEE ATTACHMENT 9	
17. SEE ATTACHMENT 9	
18. SEE ATTACHMENT 9	
19. SEE ATTACHMENT 9	
20. SEE ATTACHMENT 9	
21. SEE ATTACHMENT 9	
22. SEE ATTACHMENT 9	
23. SEE ATTACHMENT 9	
24. SEE ATTACHMENT 9	
25. SEE ATTACHMENT 9	
26. SEE ATTACHMENT 9	
27. SEE ATTACHMENT 9	
28. SEE ATTACHMENT 9	
29. SEE ATTACHMENT 9	
30. SEE ATTACHMENT 9	

DATE	DESCRIPTION
08/28/09	ISSUE PLAN CHECK
01/22/09	ISSUE BACK CHECK
08/18/09	BIDDING
	CONSTRUCTION

FILE NO.	DATE
01-110074	

BUILDINGS 5 & 6 RENOVATIONS

San Mateo County Community College District

BID ADDENDA

APPROVED BY THE STATE ARCHITECT
AC: JHL, FLS, SS, JMS
APPL NO. 110074, DATE 2/17/10

CAÑADA COLLEGE
4200 Farm Hill Boulevard
Redwood City, CA 94061

CASEWORK AND SPECIALTY DETAILS

Date: 08/29/08
Drawing Number: A10.62
Scale: AS NOTED
Project Number: 07013

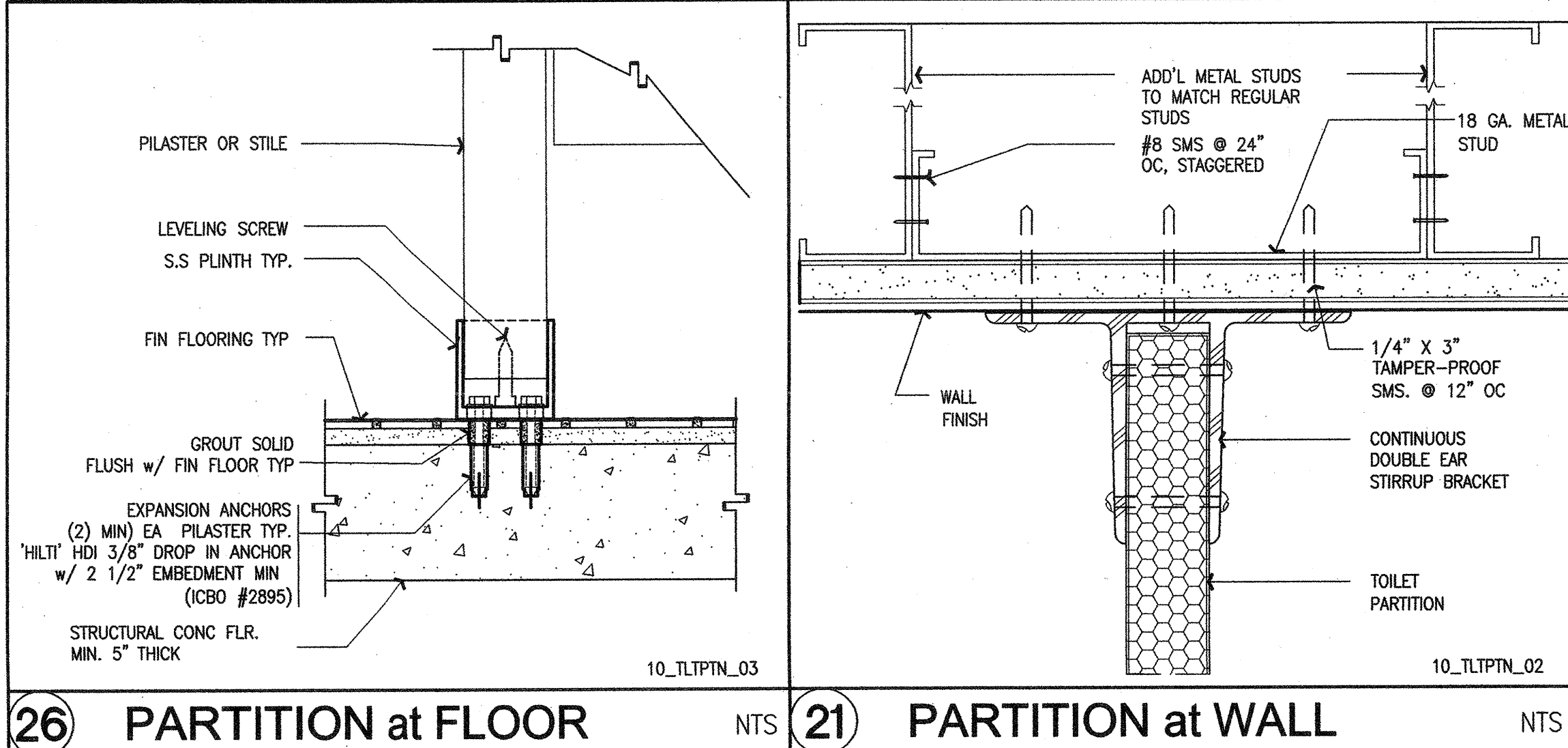

26 PARTITION at FLOOR NTS

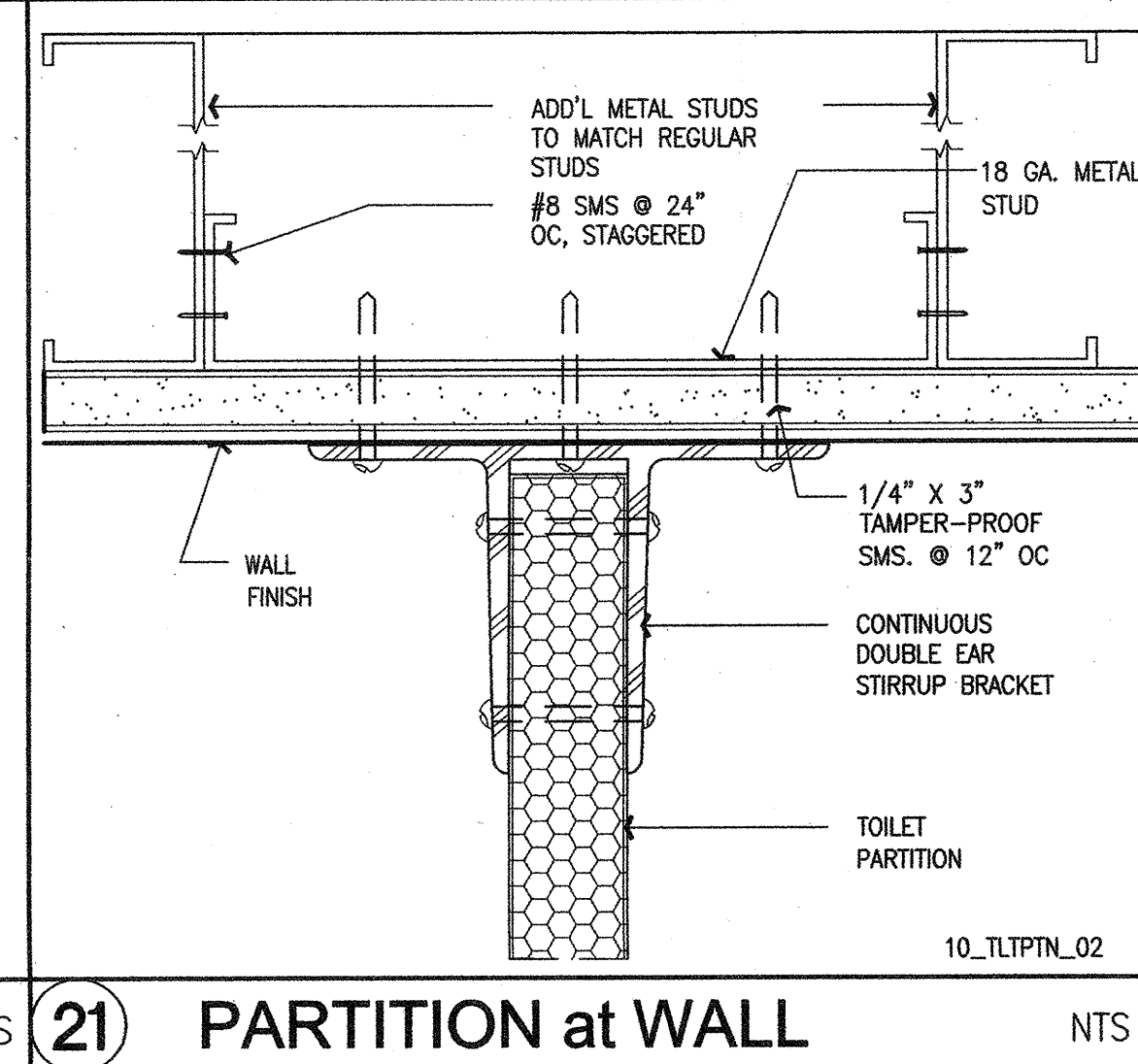

21 PARTITION at WALL NTS

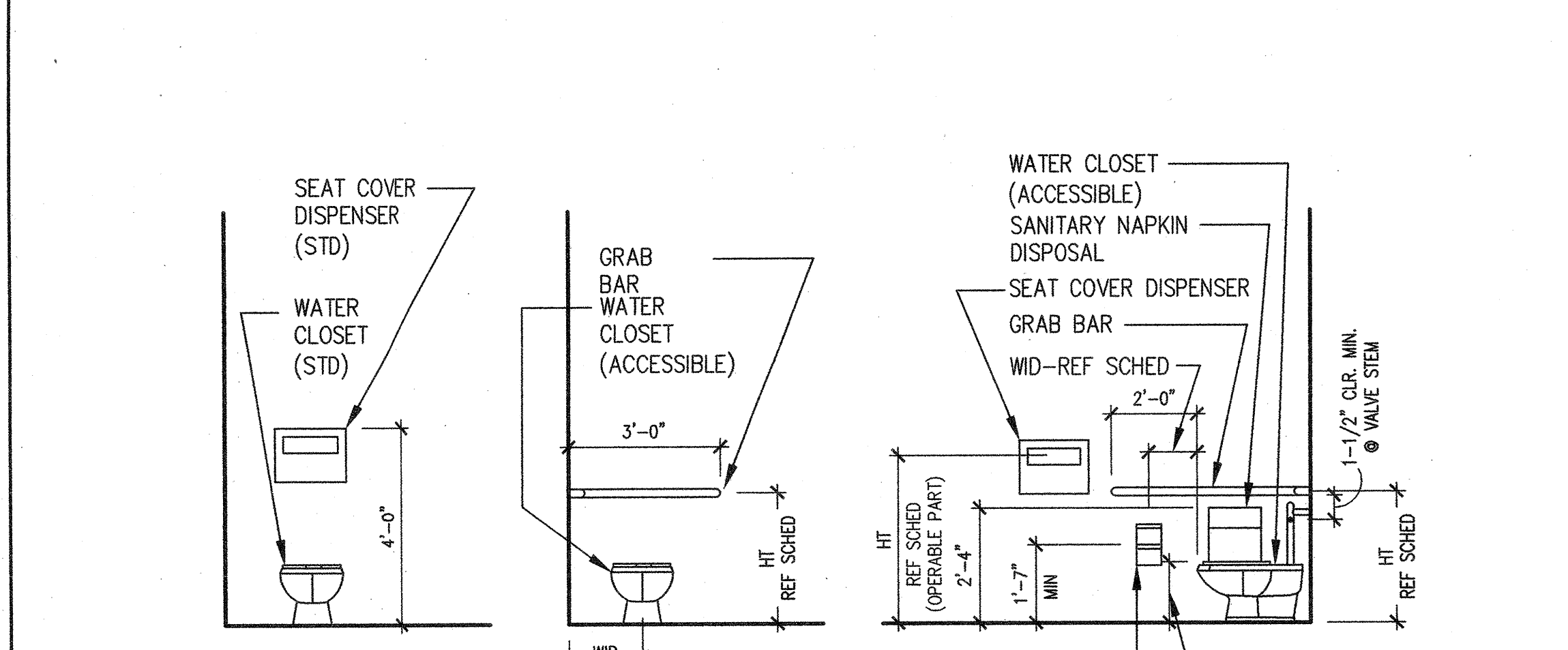

17 TYP. TOILET PARTITION

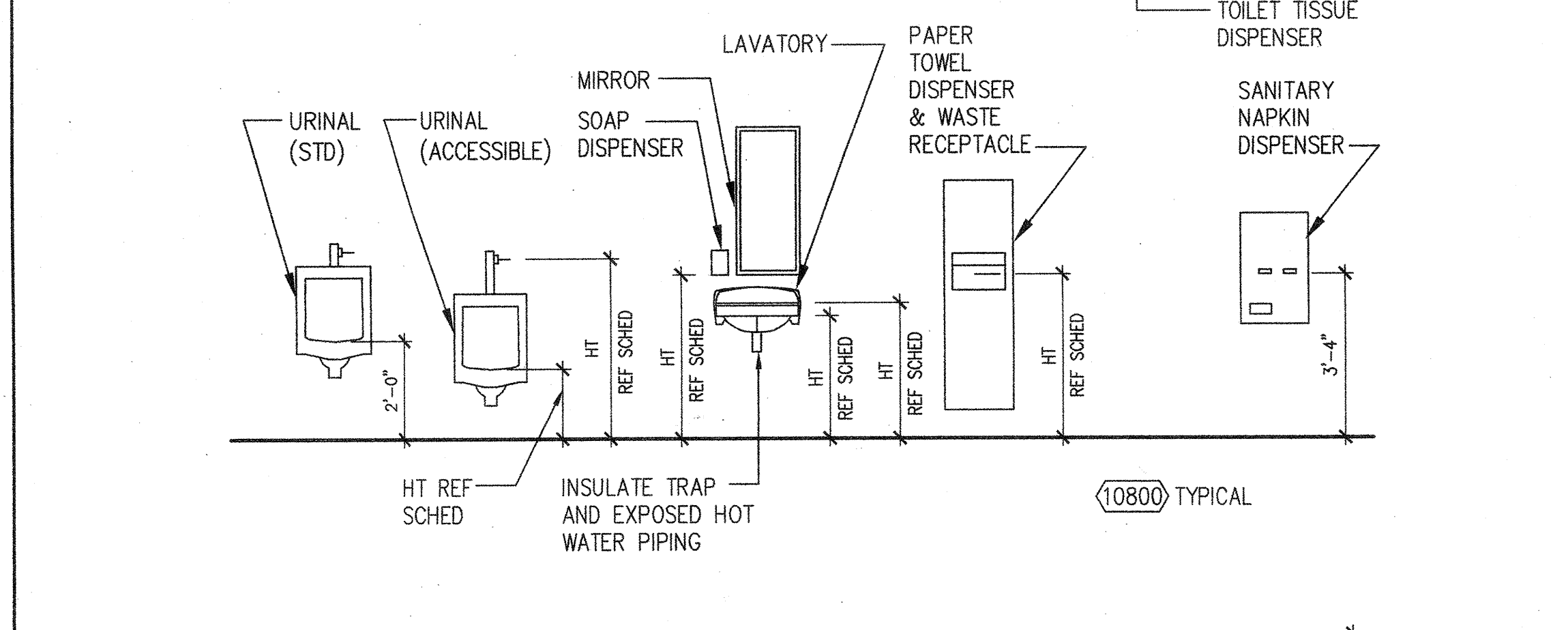

18 DRINKING FOUNTAIN 1" = 1'-0"

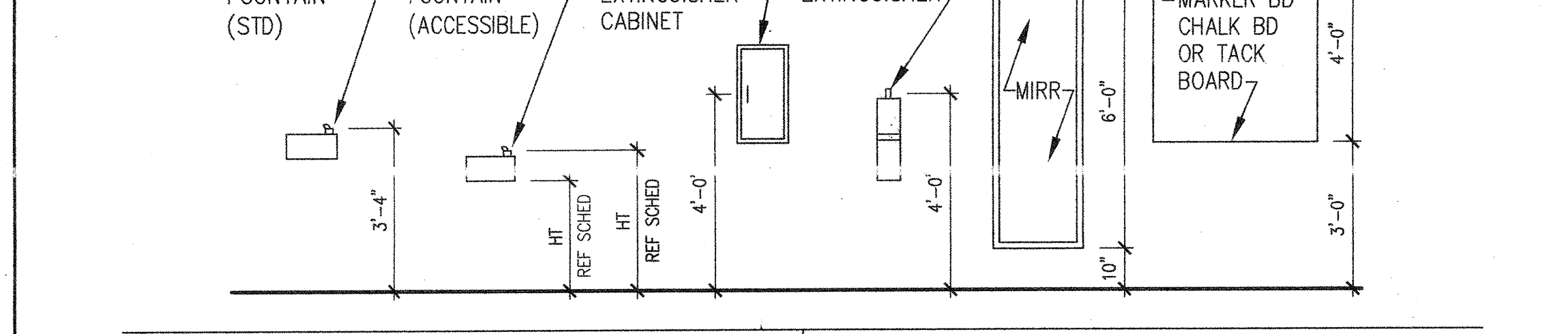

19 DRINKING FOUNTAIN 1" = 1'-0"

FIXTURE	DIMENSION (PER TABLE 1115B-1C-CBC)
TOILET CENTER LINE FROM WALL	1'-6"
TOILET SEAT HEIGHT (TOP OF SEAT)	1'-5" - 1'-7"
GRAB BAR HEIGHT (SIDE)	2'-9"
TOILET PAPER IN FRONT OF TOILET	1'-0" MAX
NAPKIN DISPOSAL IN FRONT OF TOILET	1'-0" MAX
DISPENSER OR MIRROR HEIGHT	3'-4" MAX
LAVATORY/SINK TOP HEIGHT	2'-10" MAX
LAVATORY/SINK KNEE CLEARANCE	2'-3" MIN
URINAL LIP HEIGHT	1'-5" MAX
URINAL FLUSH HANDLE HEIGHT	3'-8" MAX
DRINKING FOUNTAIN BUBBLER HEIGHT	3'-0" MAX
DRINKING FOUNTAIN KNEE CLEARANCE	2'-3" MIN
RAMP/STAIR HANDRAIL HEIGHT	2'-10" - 3'-2"

LEGEND
A = ADULT DIMENSIONS (AGE 12 AND OVER)

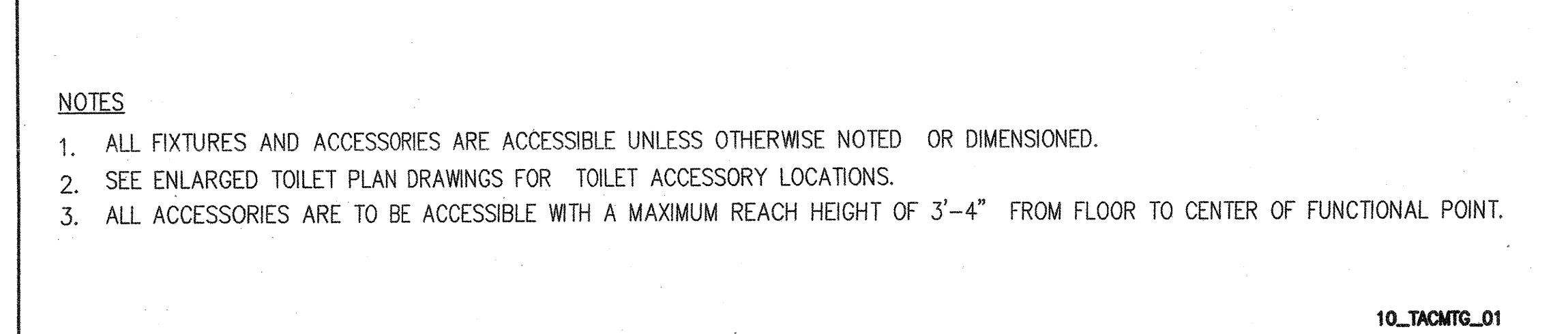

30 MOUNTING HEIGHT SCHEDULE 3/8" = 1'-0"

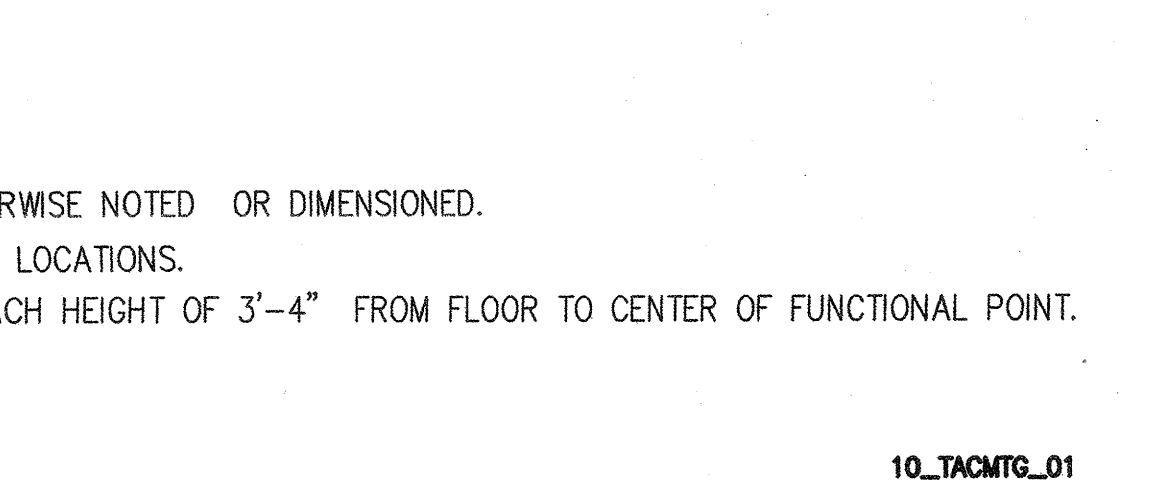

20 ANCHOR @ WALL N.T.S.

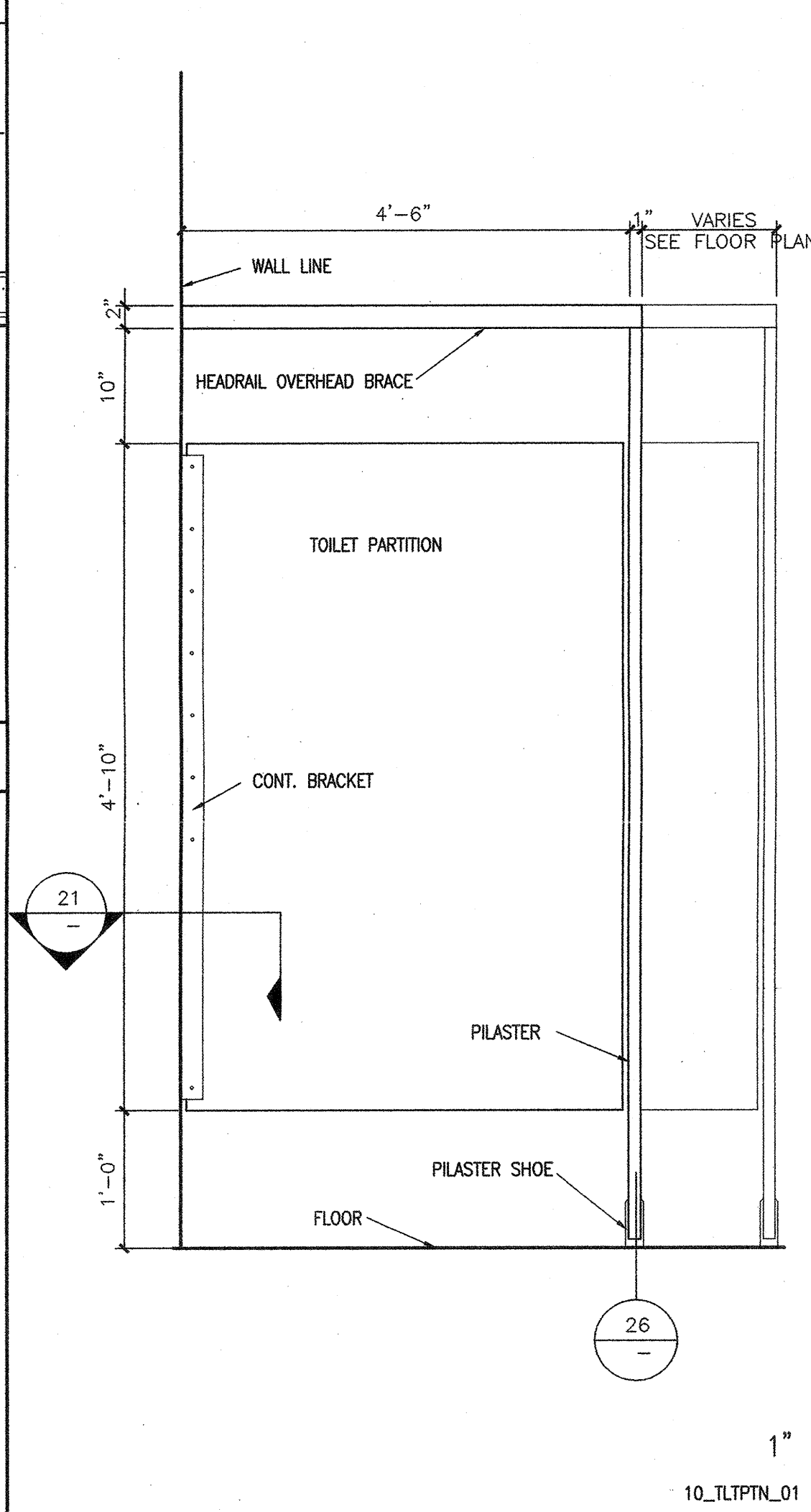

17 TYP. TOILET PARTITION

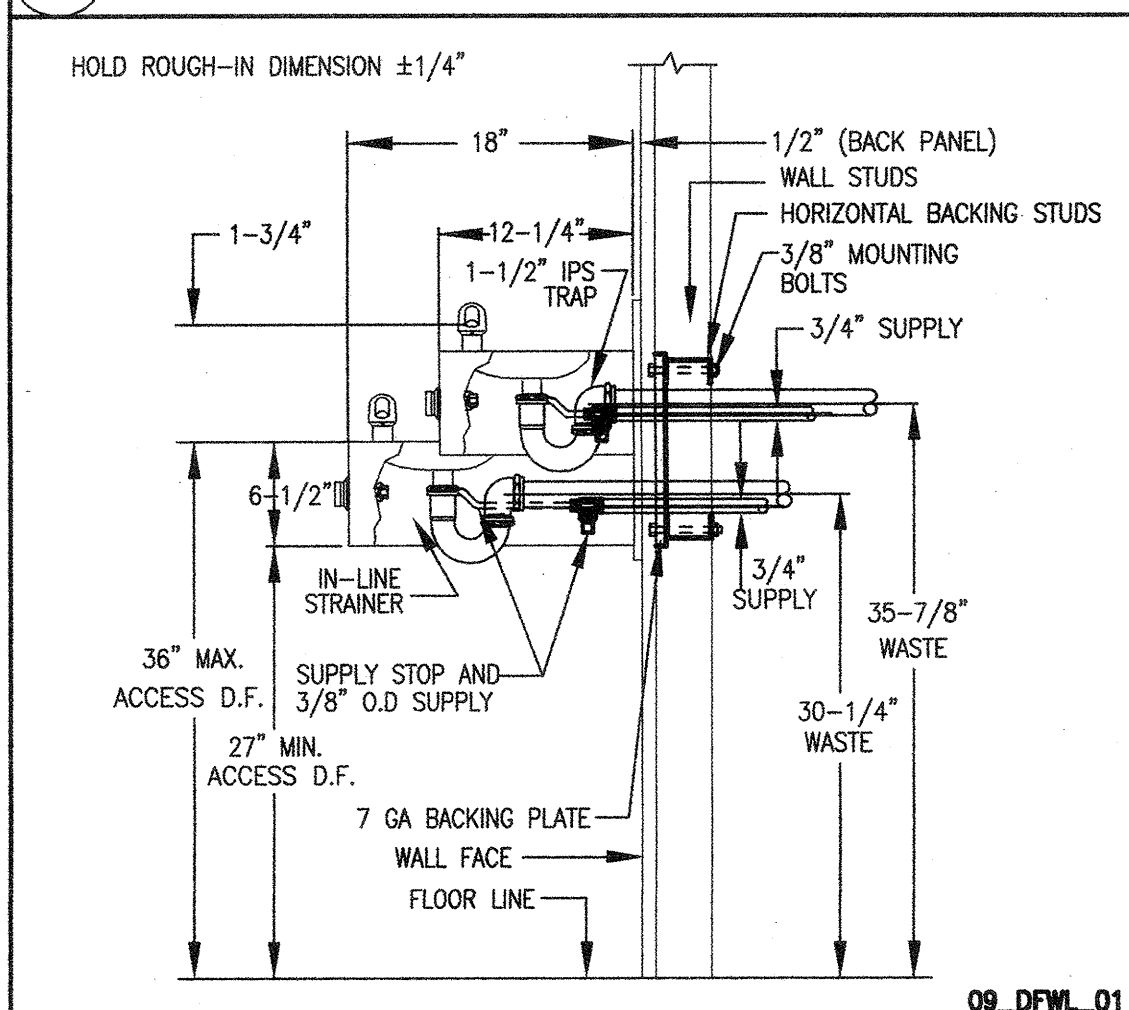

18 DRINKING FOUNTAIN 1" = 1'-0"

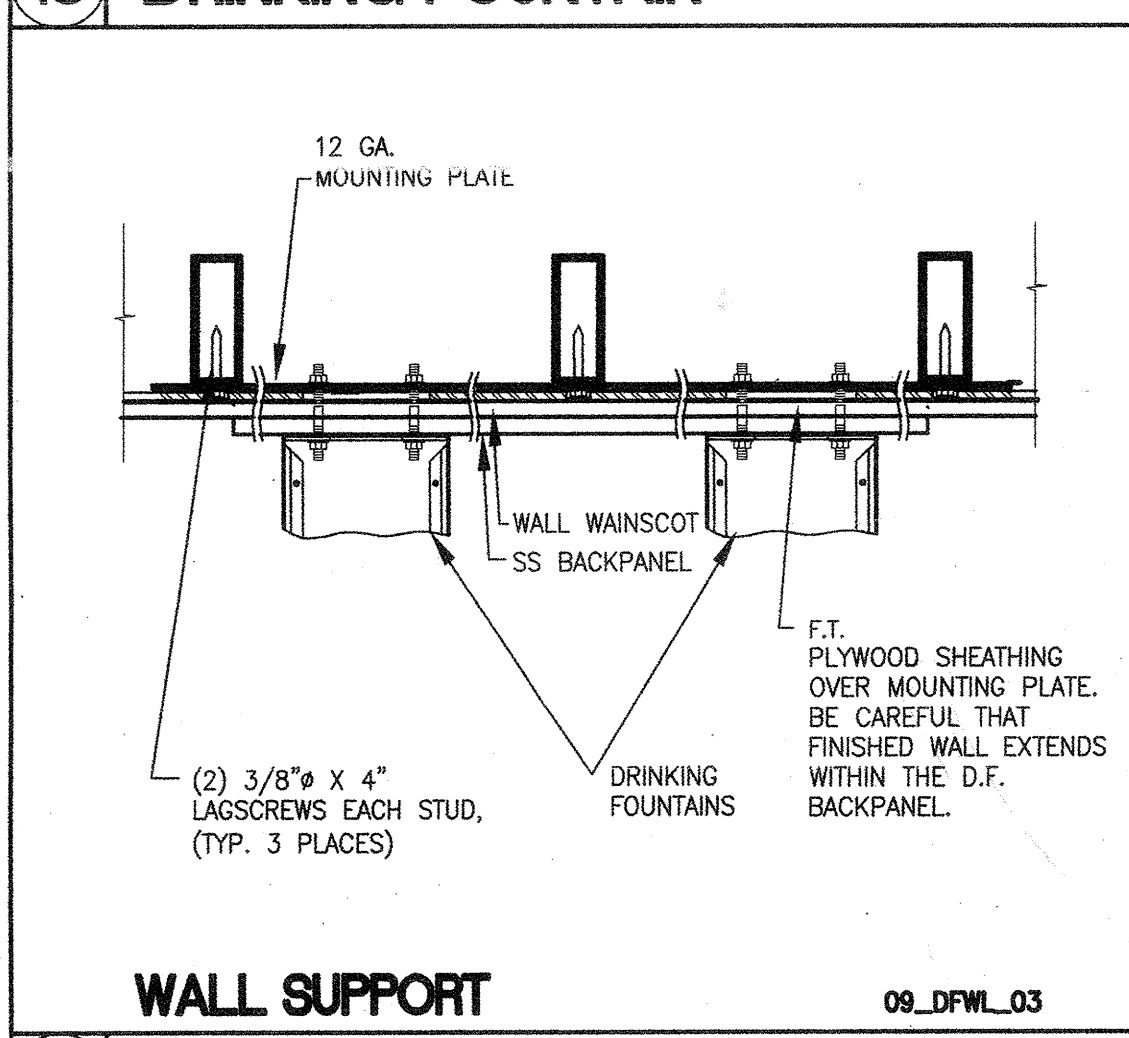

19 DRINKING FOUNTAIN 1" = 1'-0"

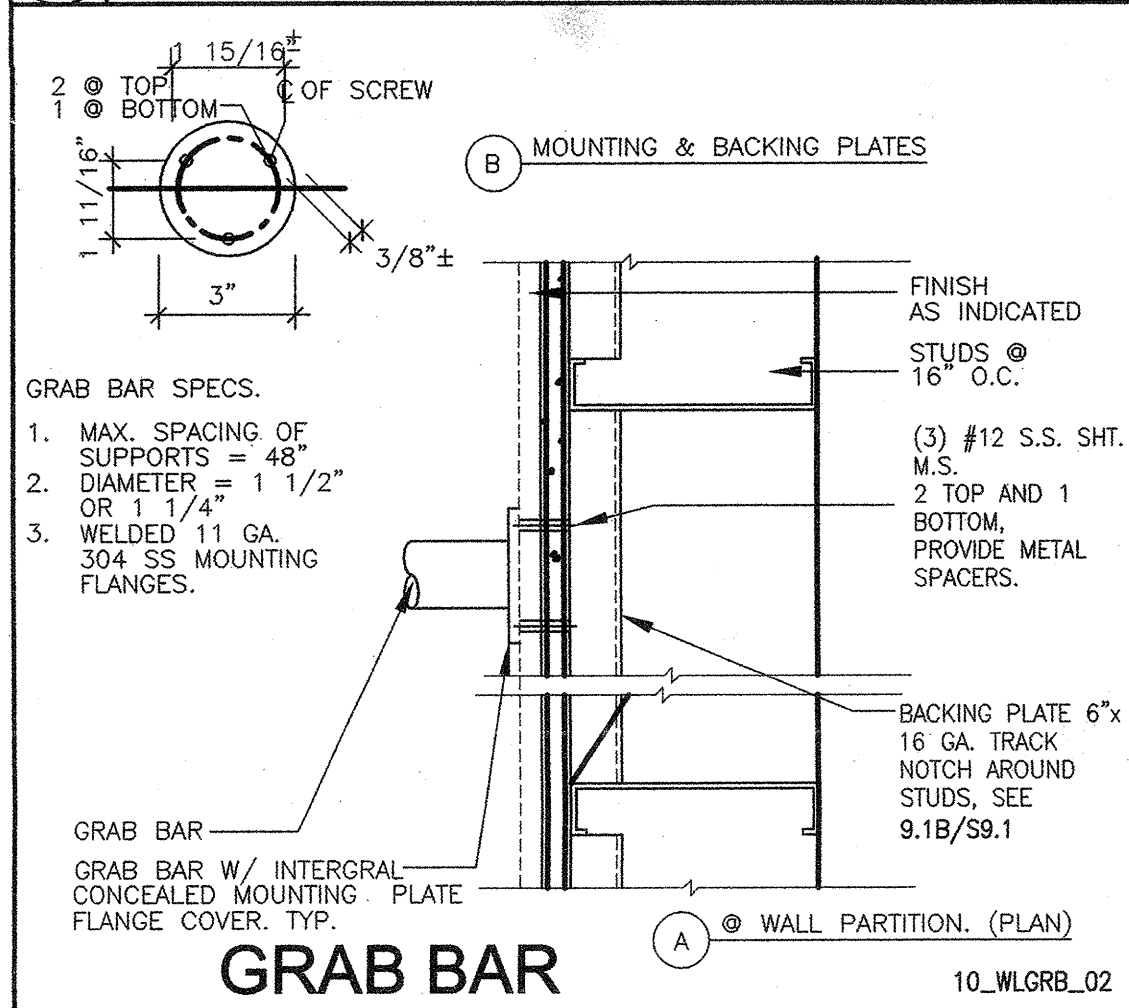

20 ANCHOR @ WALL N.T.S.

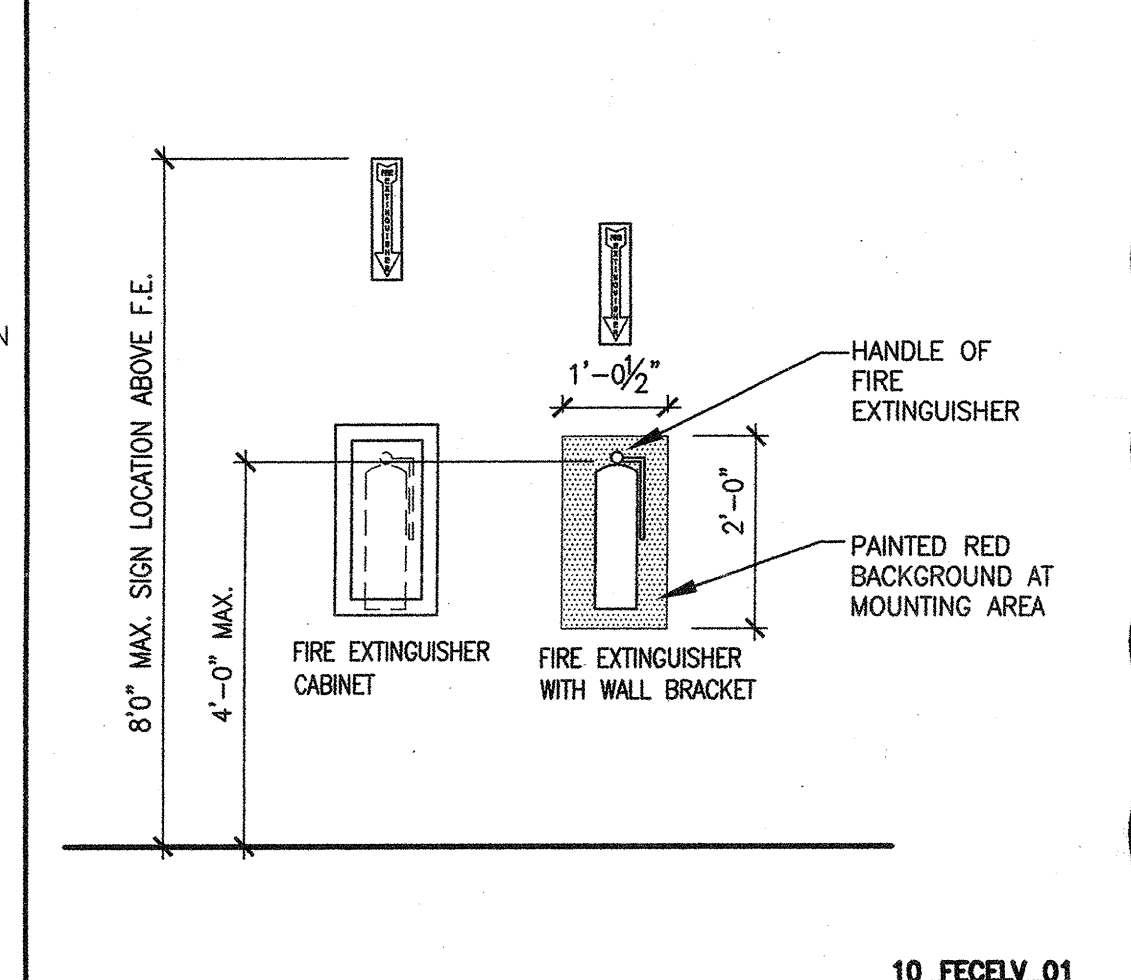

11 F.E. MOUNTING AND SIGNS 1/2" = 1'-0"

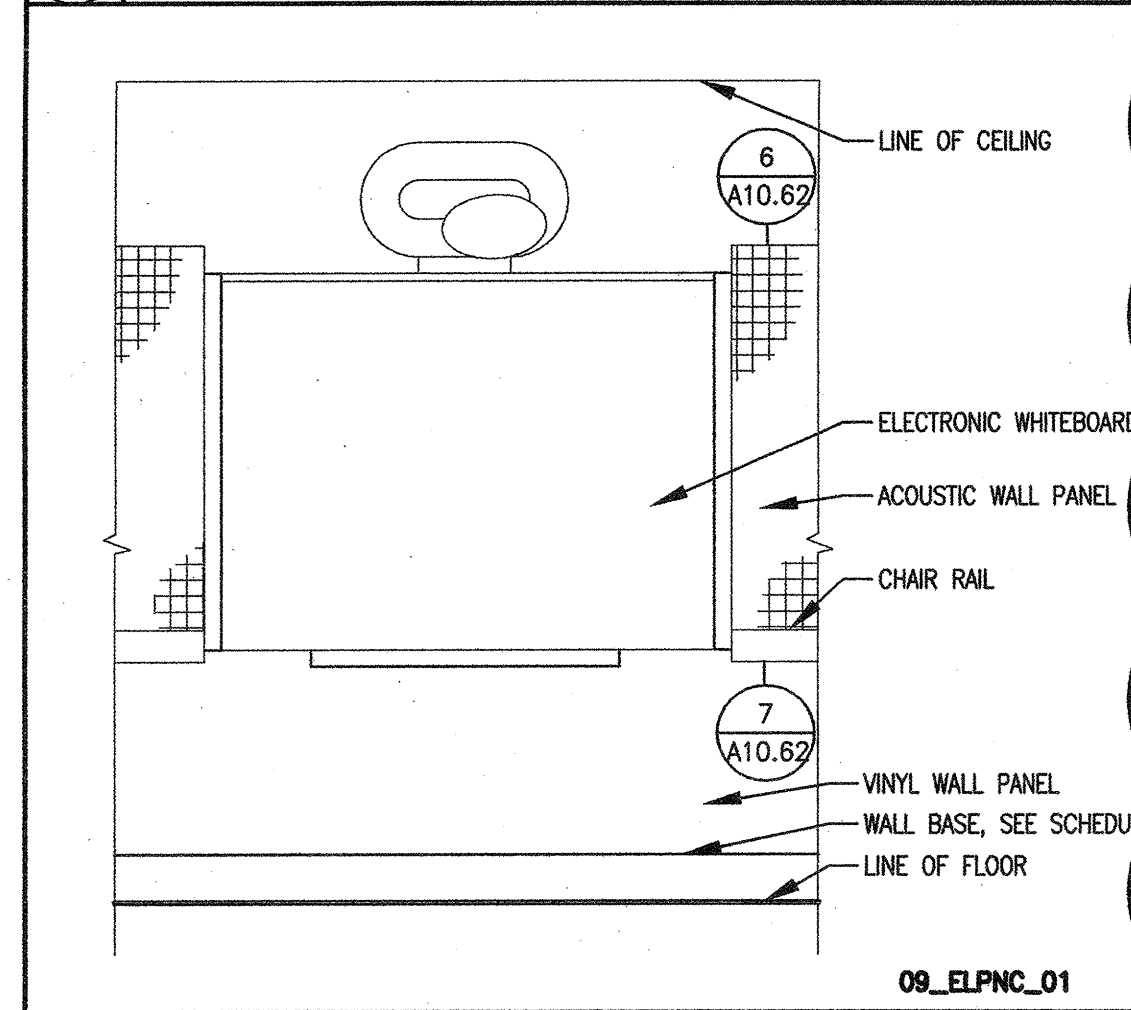

12 ELECTRONIC WHITE BD. 1/2" = 1'-0"

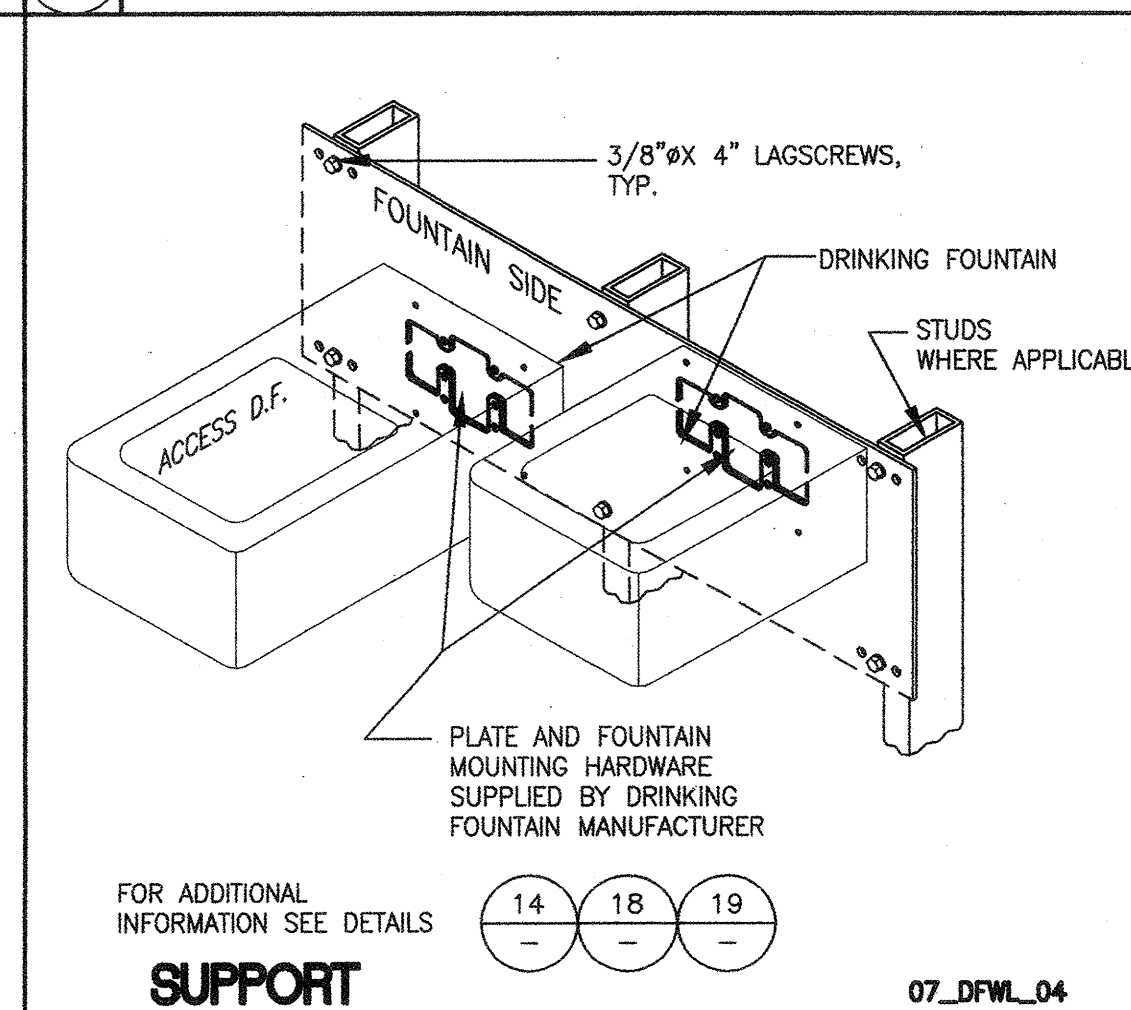

18 DRINKING FOUNTAIN 1" = 1'-0"

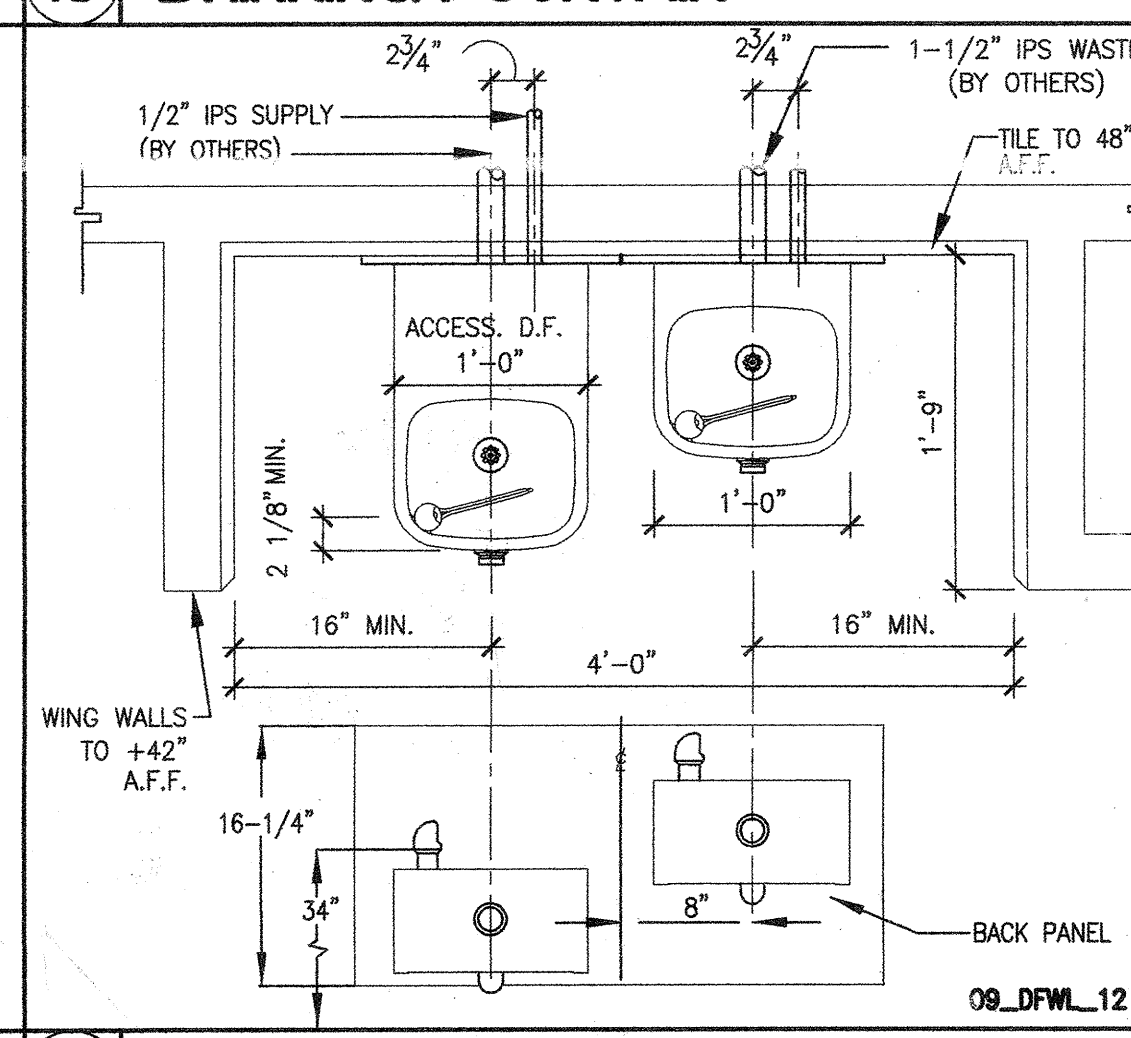

19 DRINKING FOUNTAIN 1" = 1'-0"

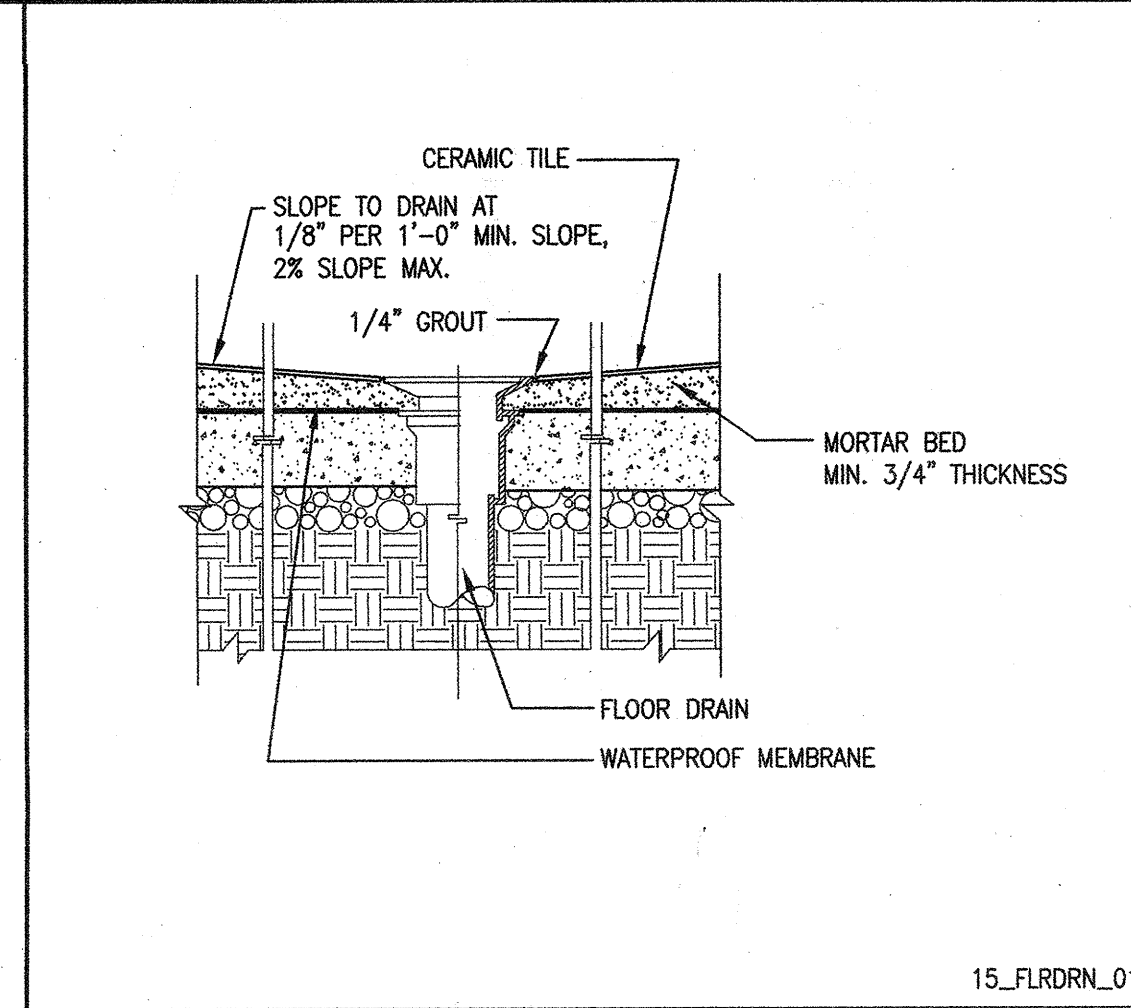

15 FLOOR DRAIN 1"

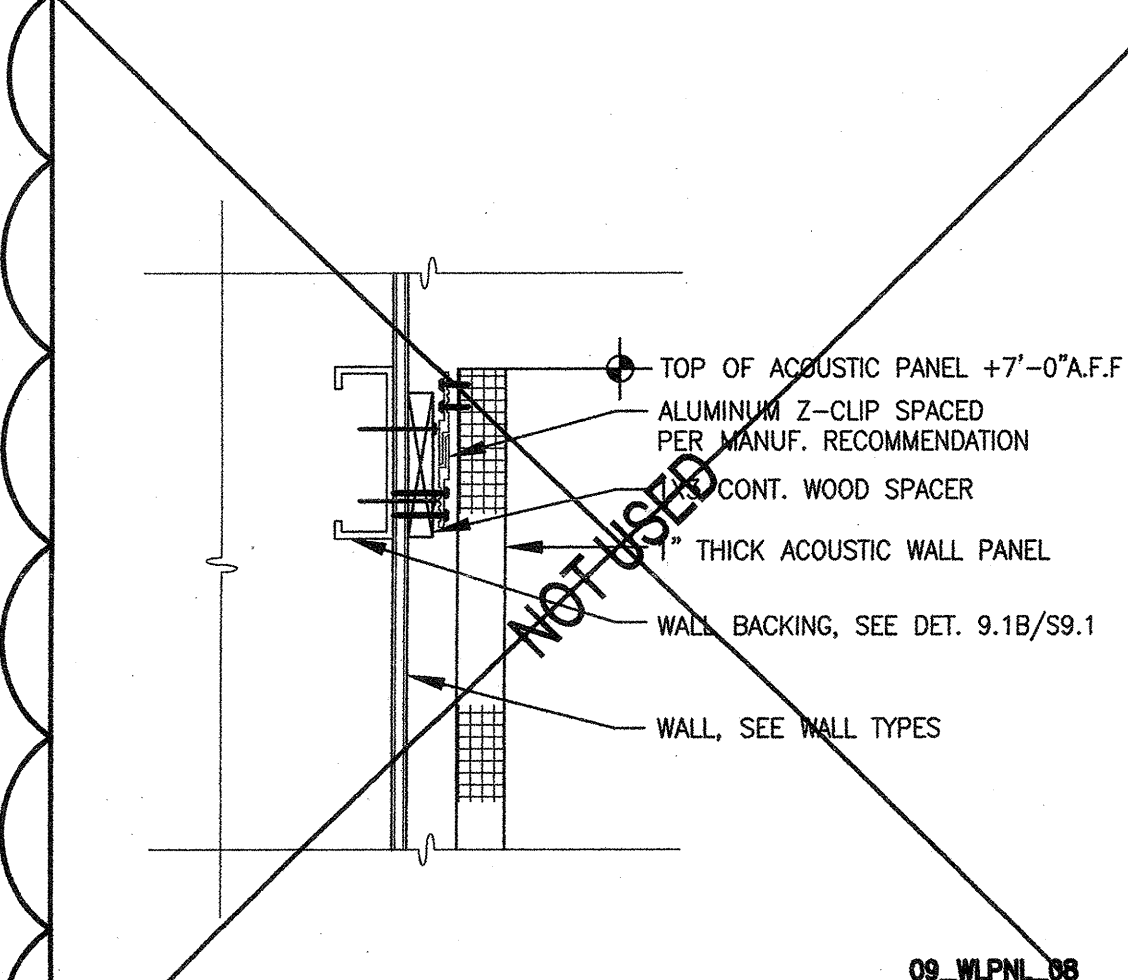

8 ACOUSTIC WALL PANEL (TOP) 3" = 1'-0"

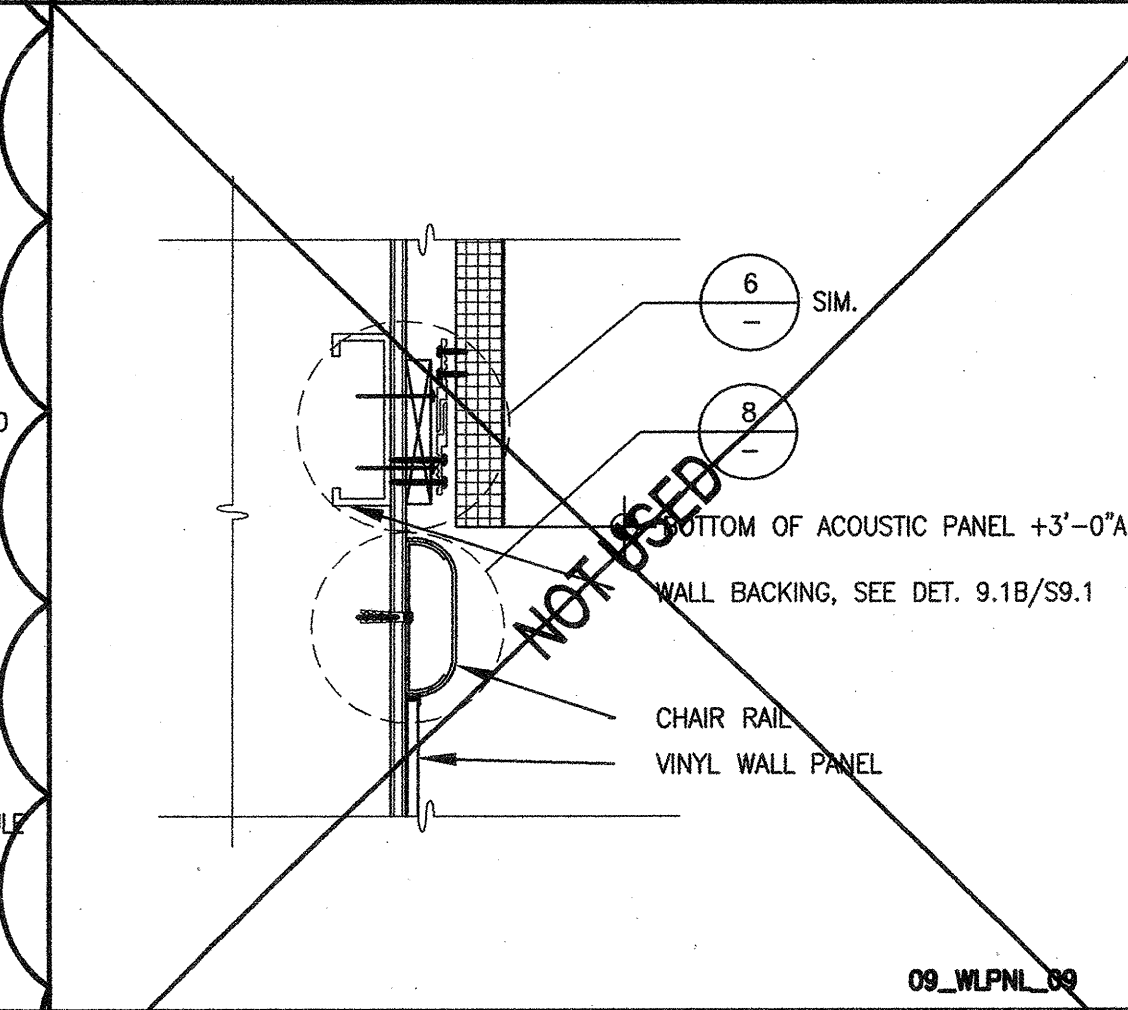

12 ELECTRONIC WHITE BD. 1/2" = 1'-0"

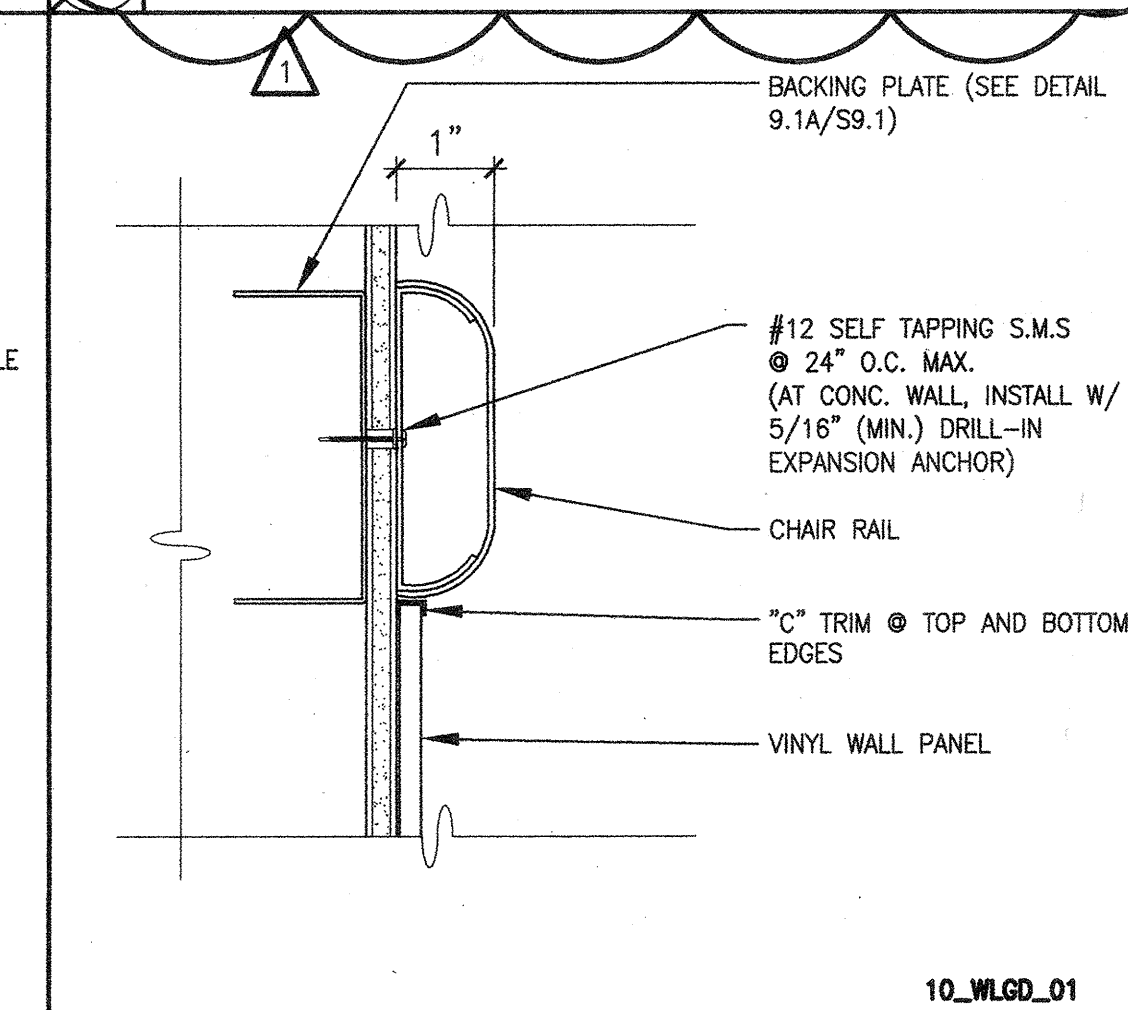

8 CHAIR RAIL 6" = 1'-0"

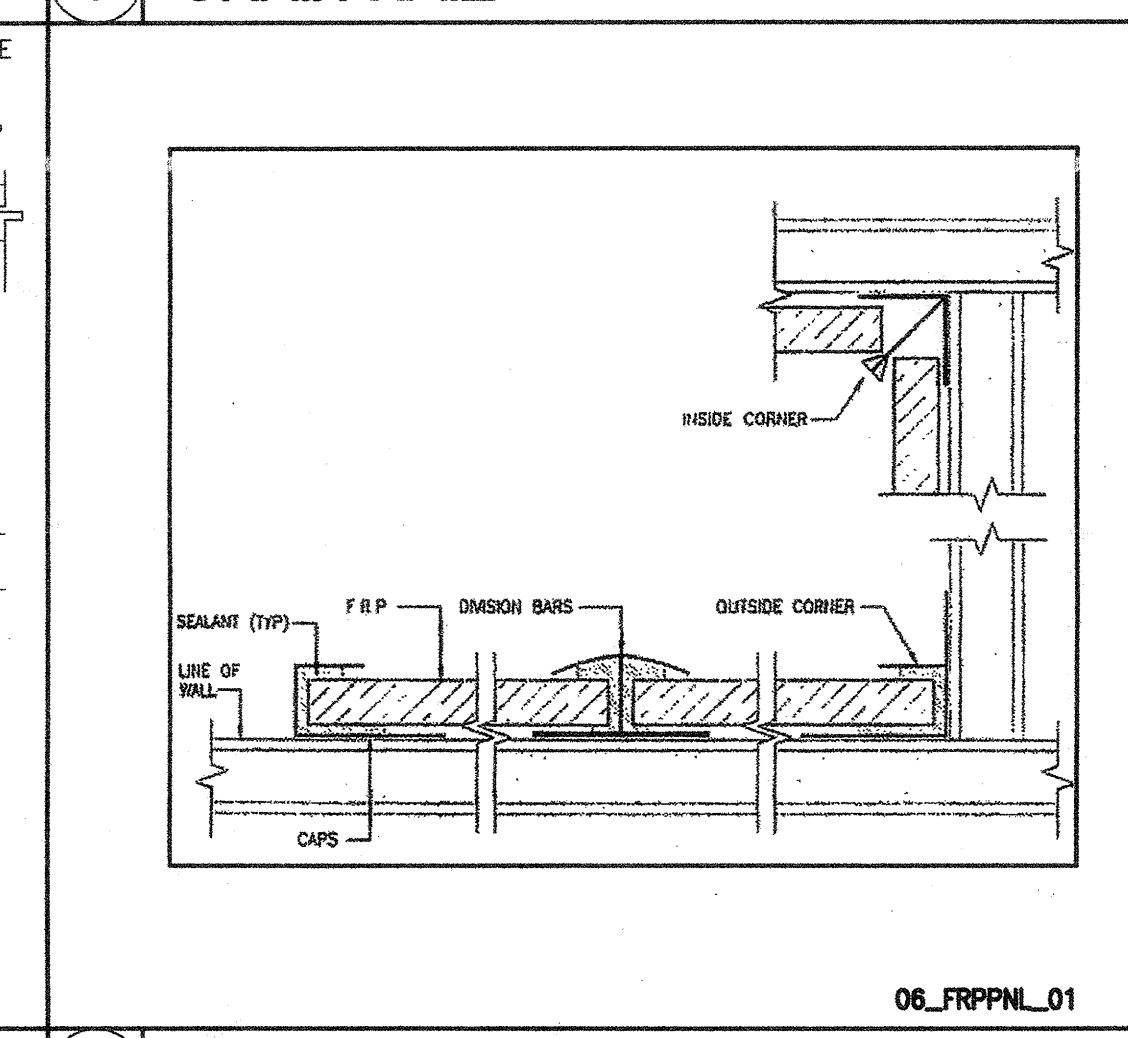

9 FRP WALL DETAILS N.T.S.

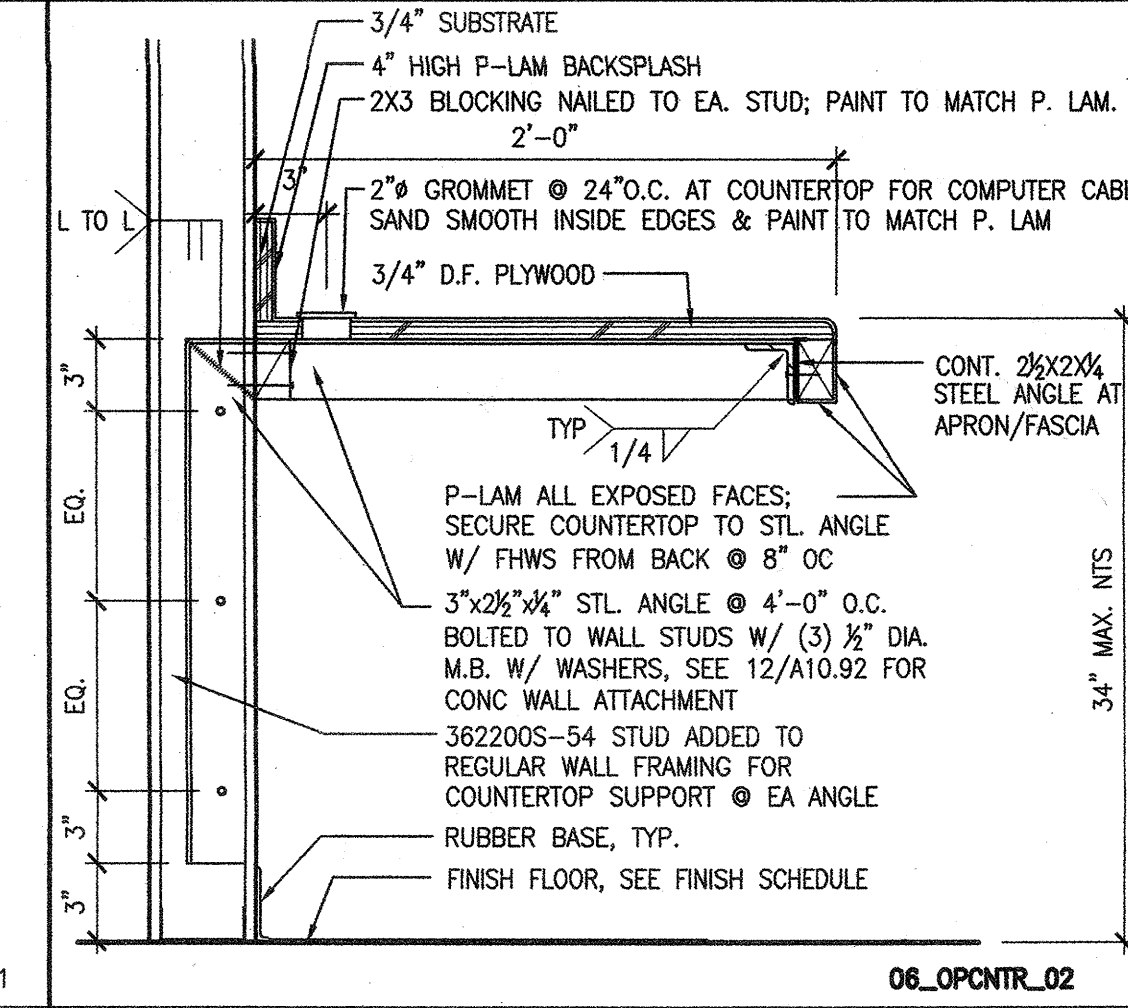

10 COUNTER W/O BASE CAB. 1-1/2" = 1'-0"

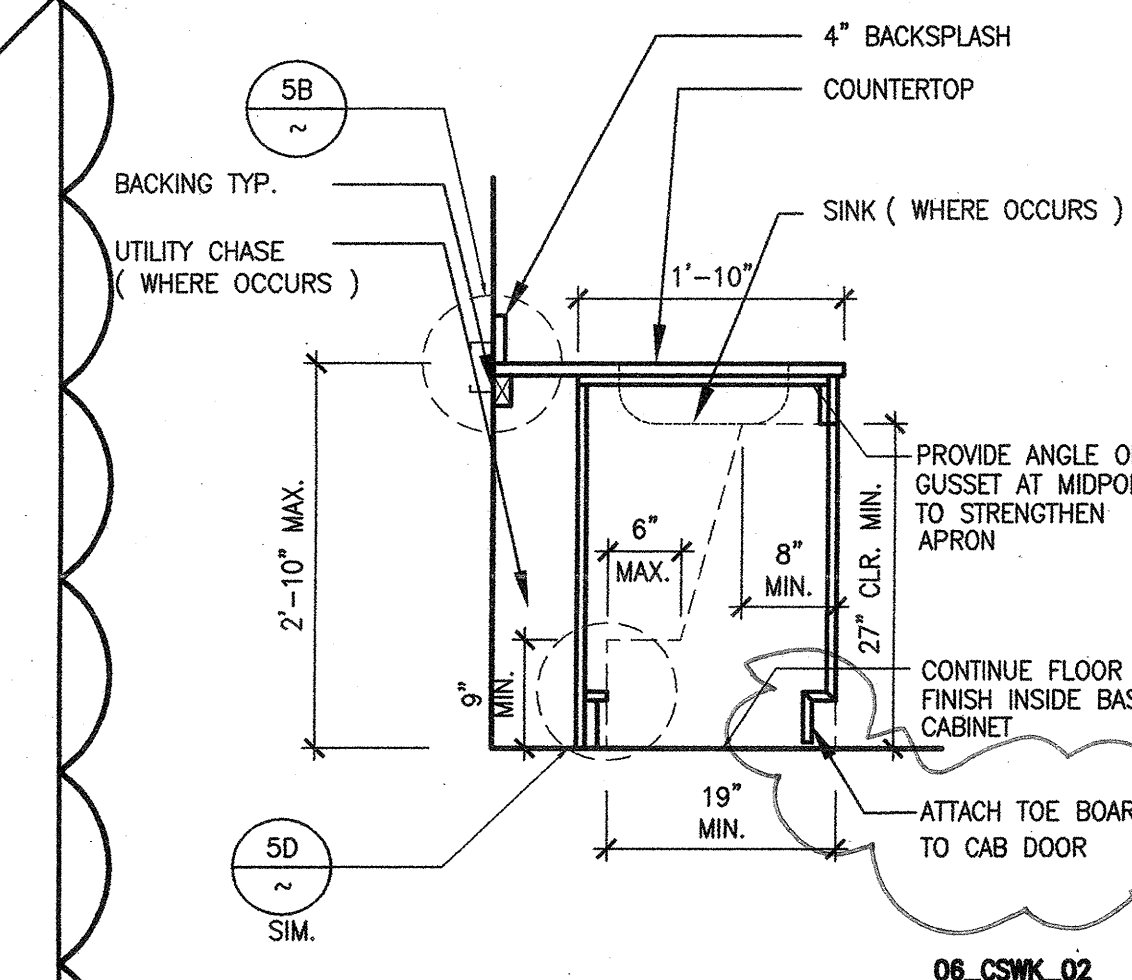

6 ACCESSIBLE BASE CAB. 3/4" = 1'-0"

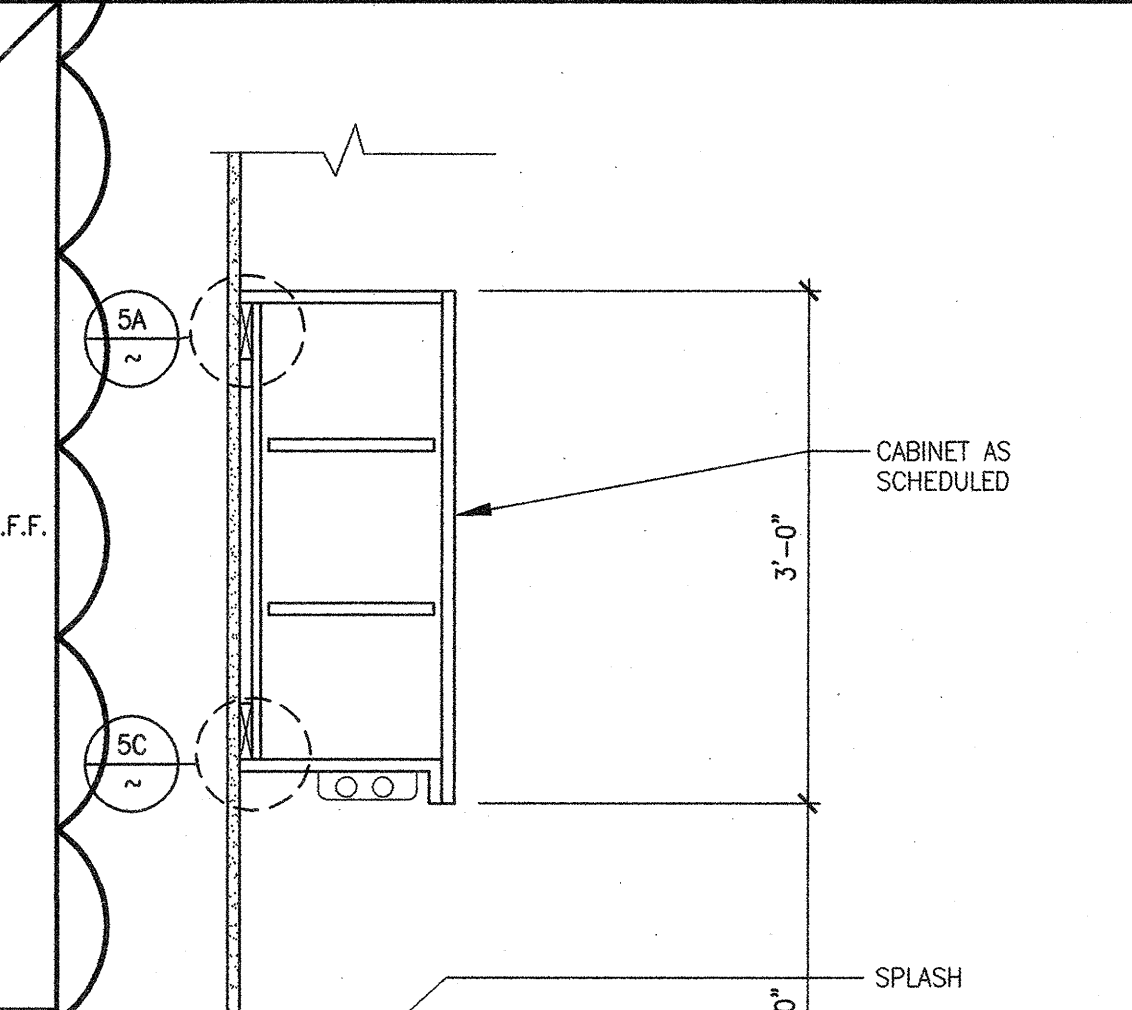

12 ELECTRONIC WHITE BD. 1/2" = 1'-0"

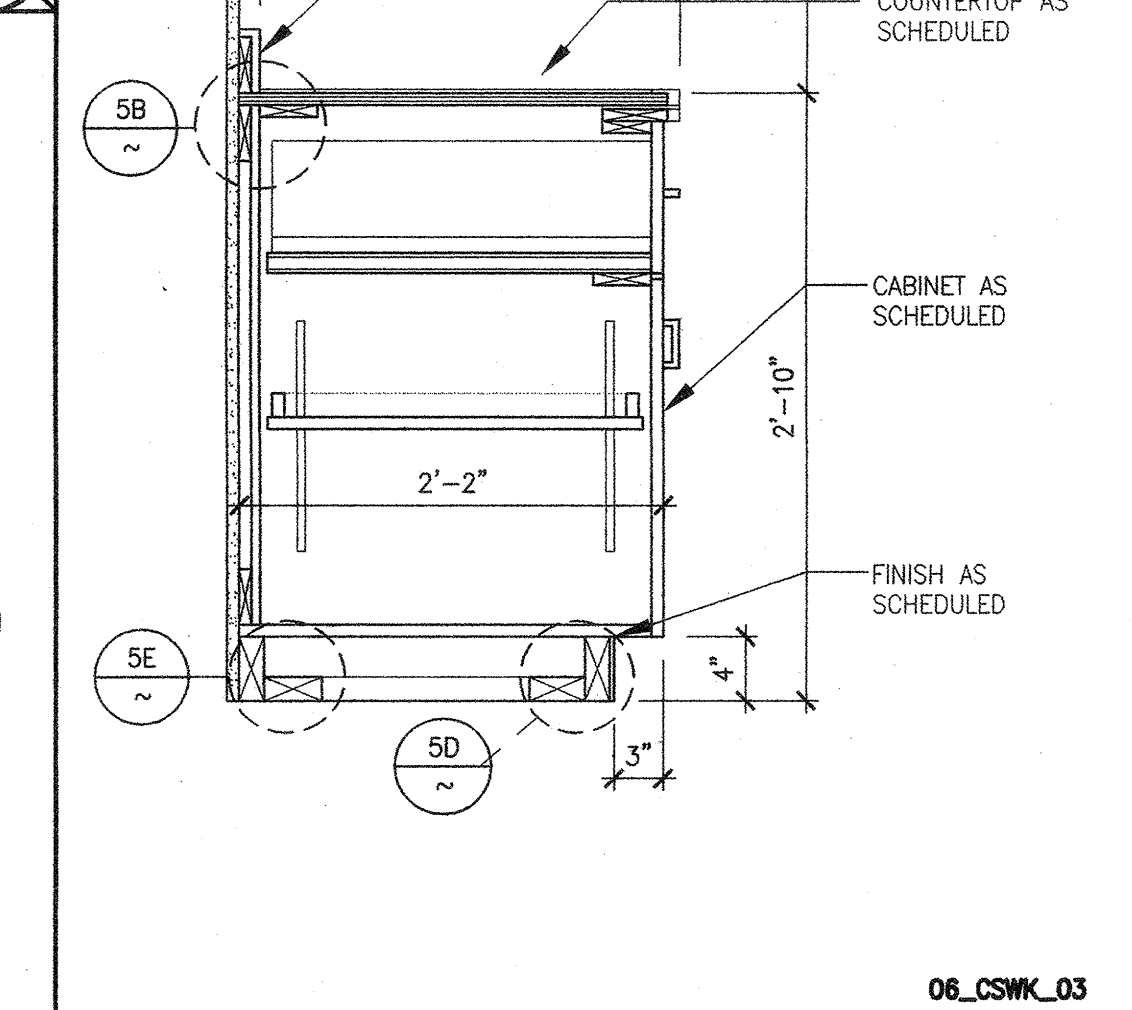

8 CHAIR RAIL 6" = 1'-0"

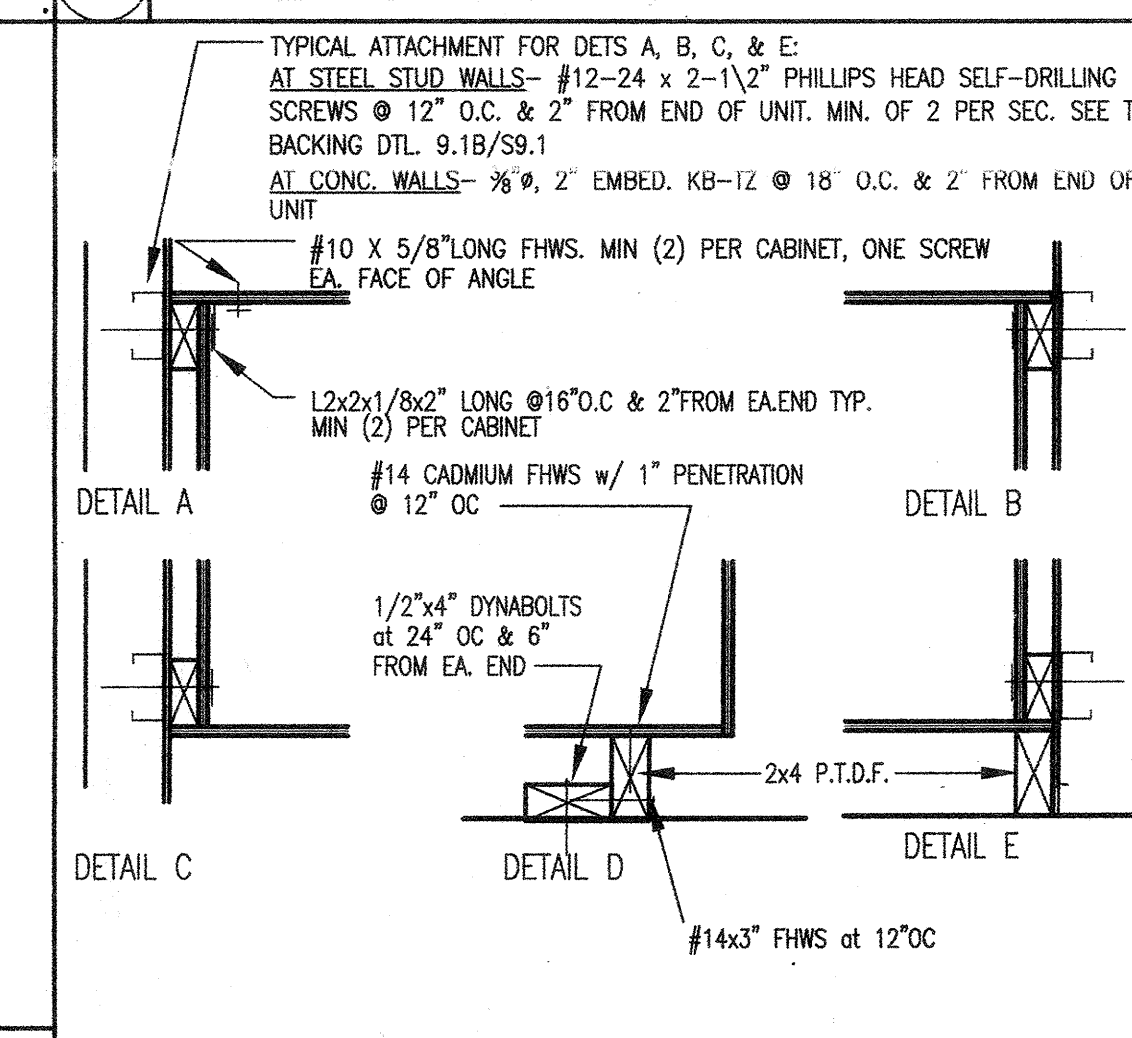

3 CABINET DETAIL 1" = 1'-0"

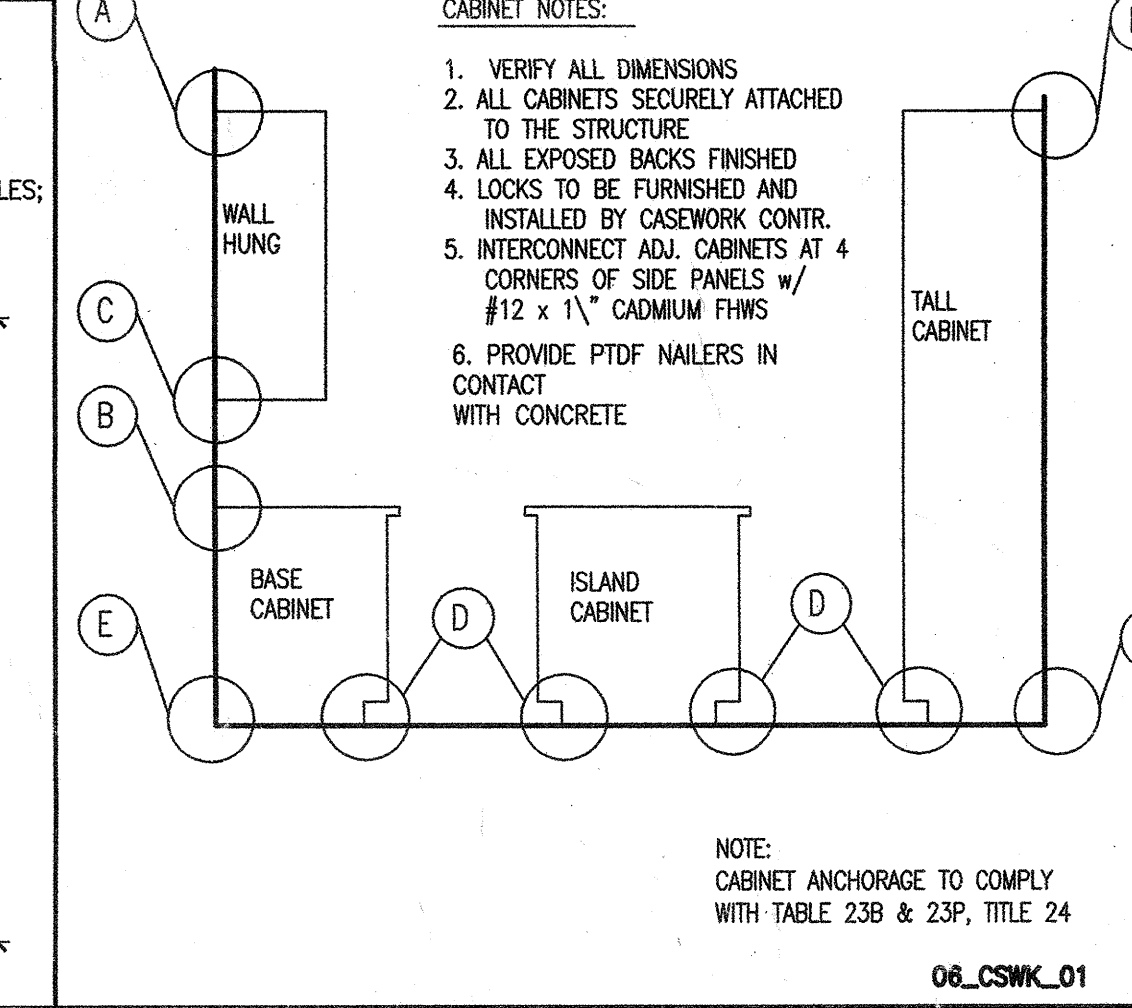

5 CASEWORK ANCHORAGE 1/2" = 1'-0"