

CONCRETE NOTCH 1" = 1'-0" DT02WDS1X 21

FREESTANDING WALL 1/2" = 1'-0" DT02WD15X 17

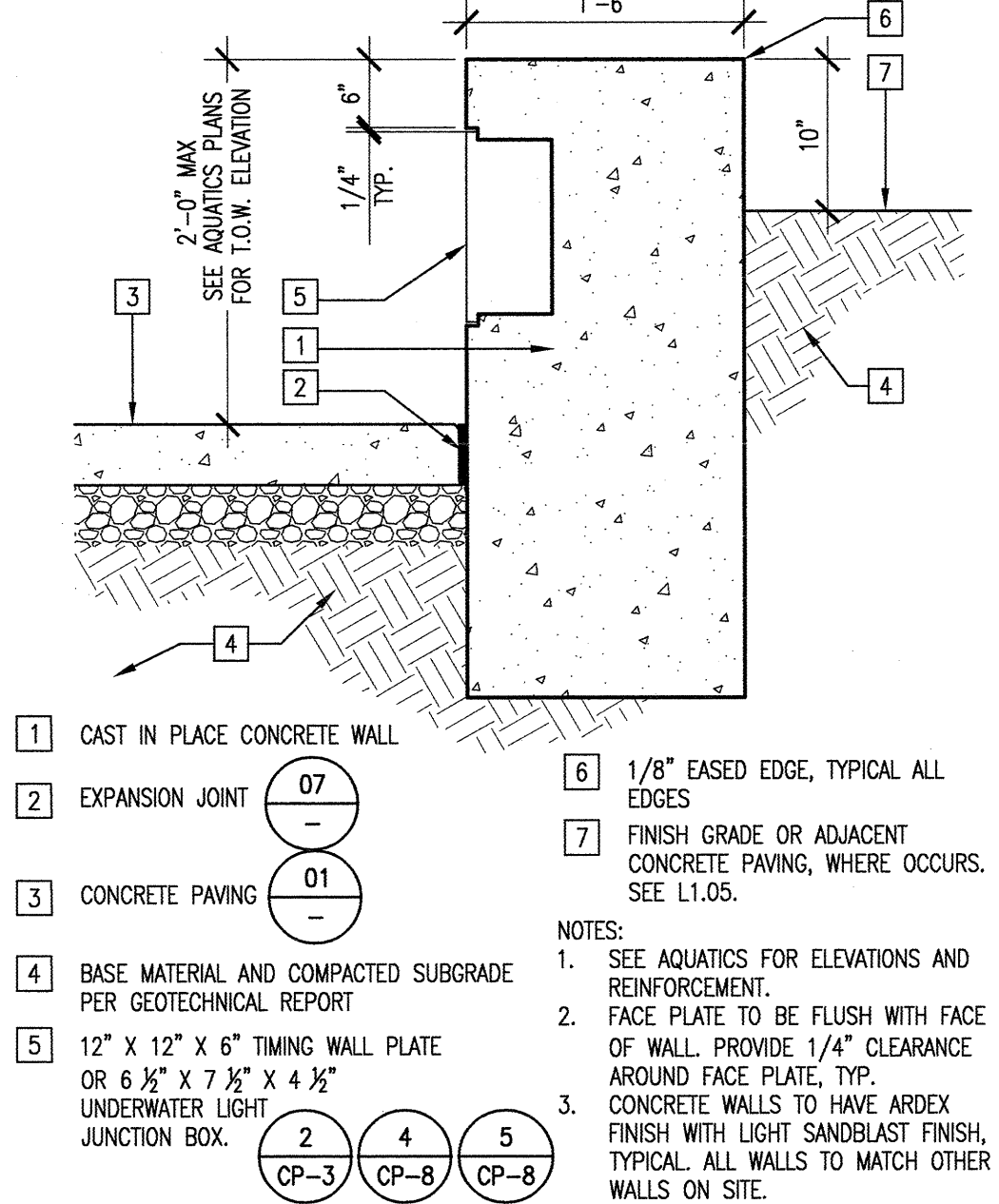

AQUATICS UTILITY WALL 1" = 1'-0" CSW-T5 22

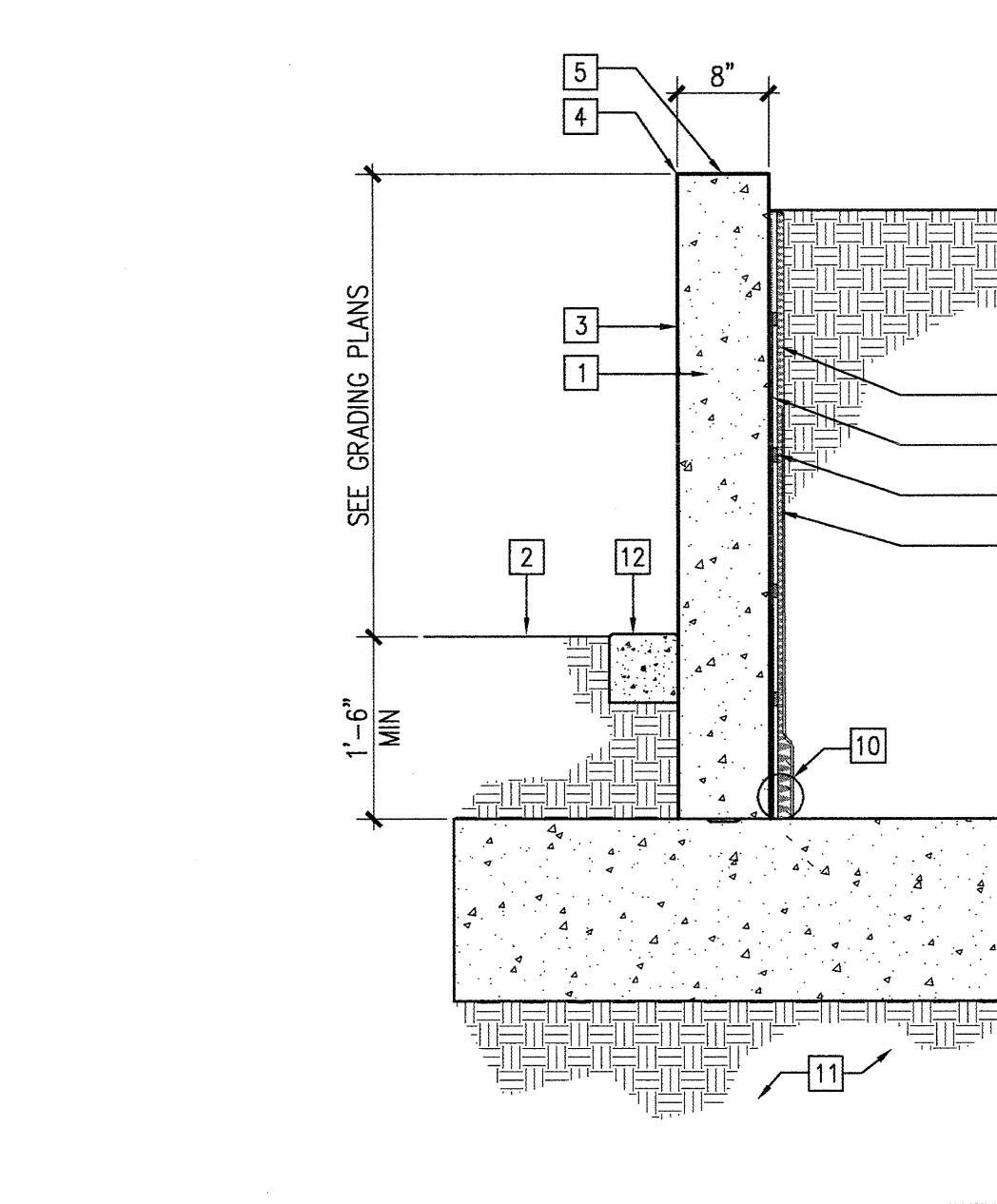

CONCRETE RETAINING WALL TYPE 4 3/4" = 1'-0" CRW-T4 14

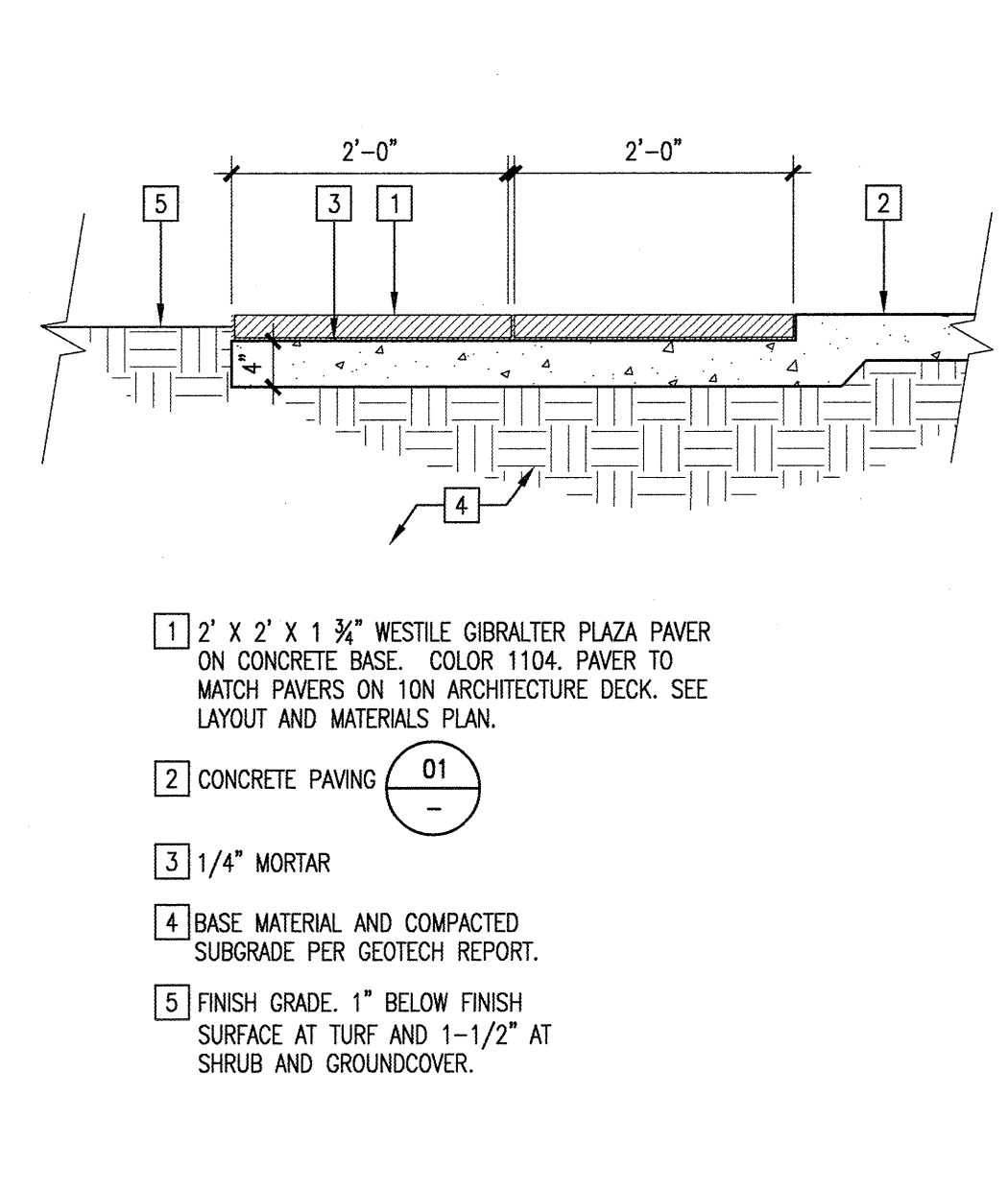

PAVERS 3/8" = 1'-0" DT02PV68 23

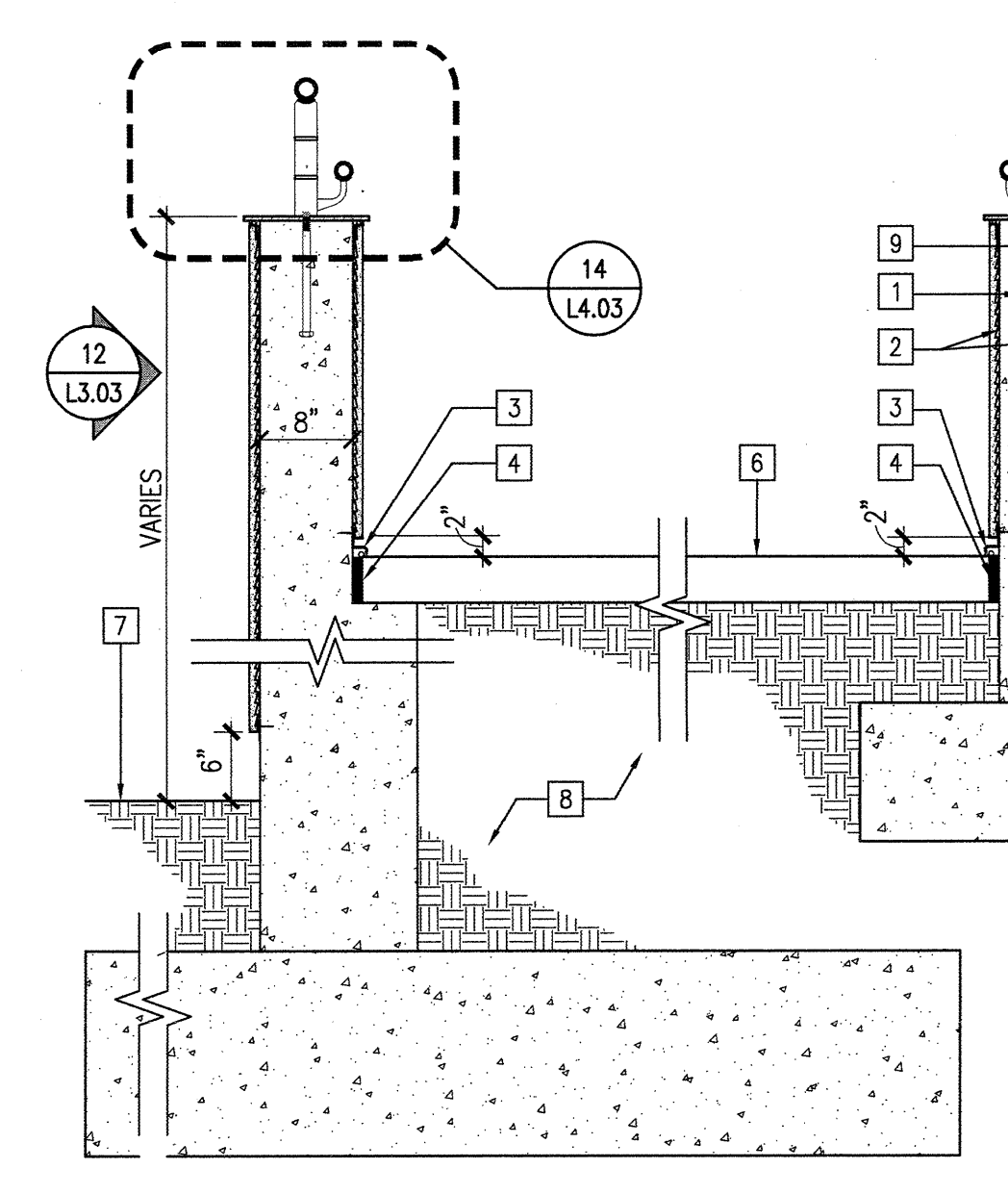

SECTION AT 10N STAIRS 3/4" = 1'-0" CRW-T2 15

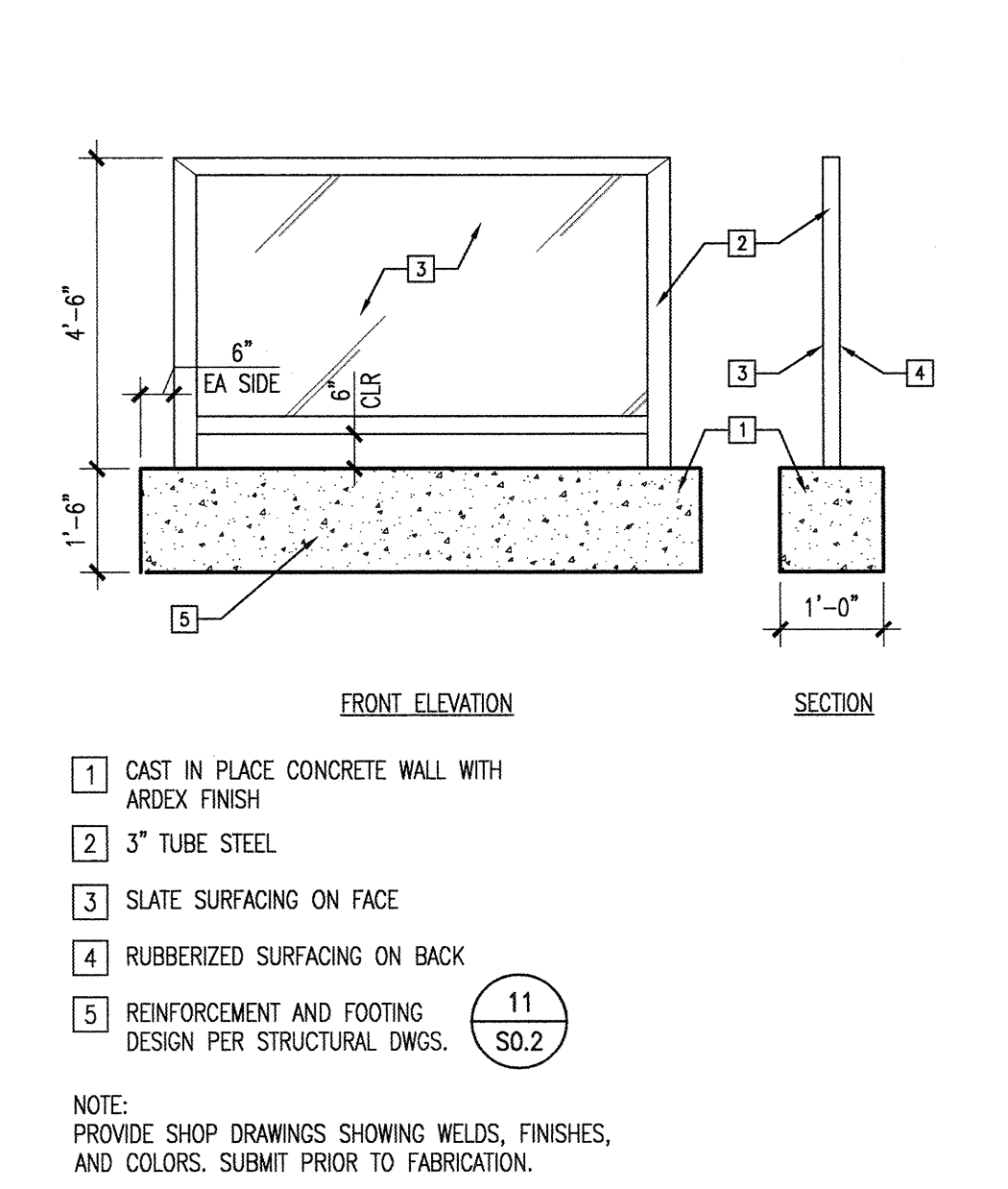

TEACHING STATION BOARD 3/8" = 1'-0" Teaching Station 24

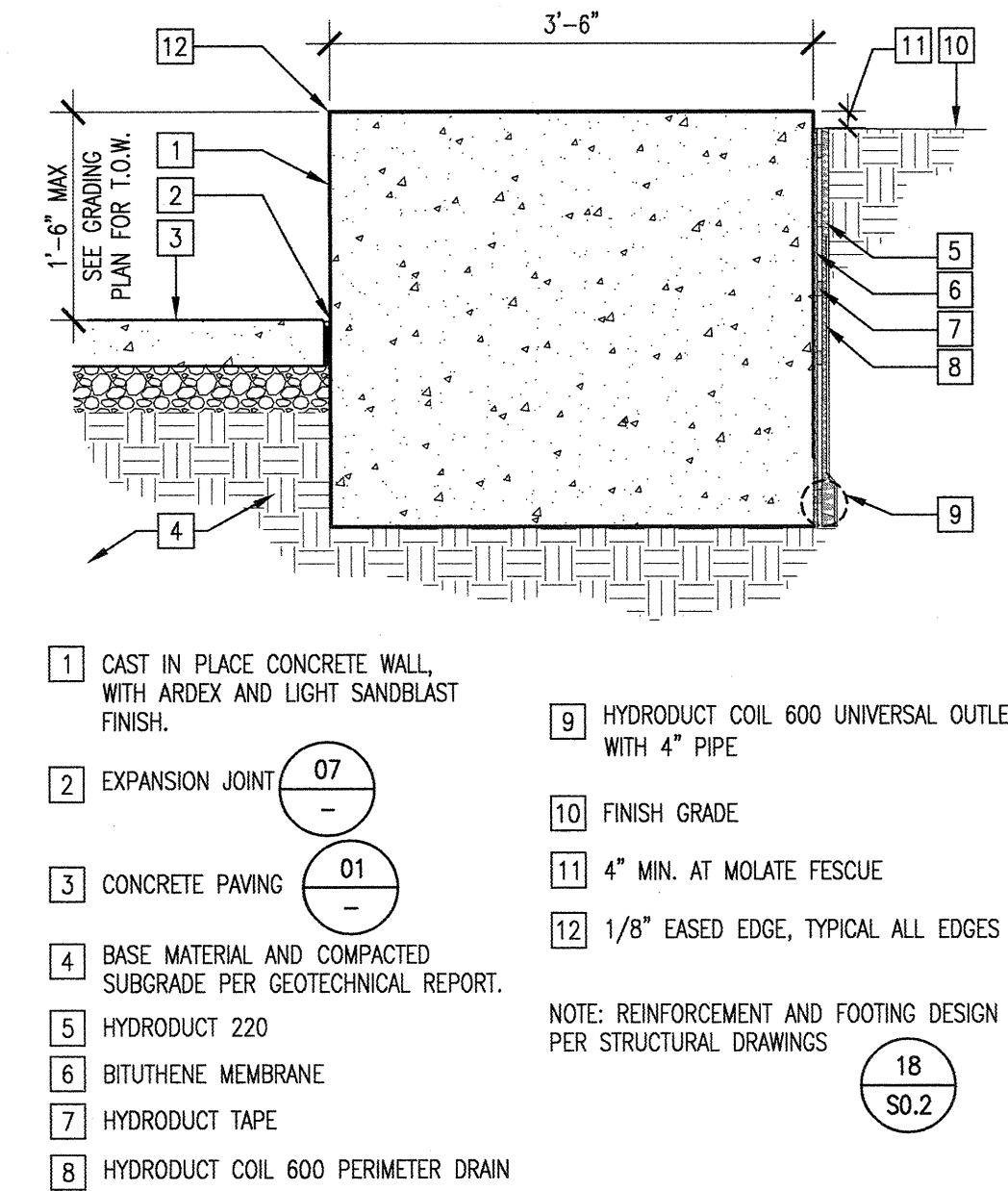

CONCRETE RETAINING WALL TYPE 8 3/4" = 1'-0" CRW-T8 20

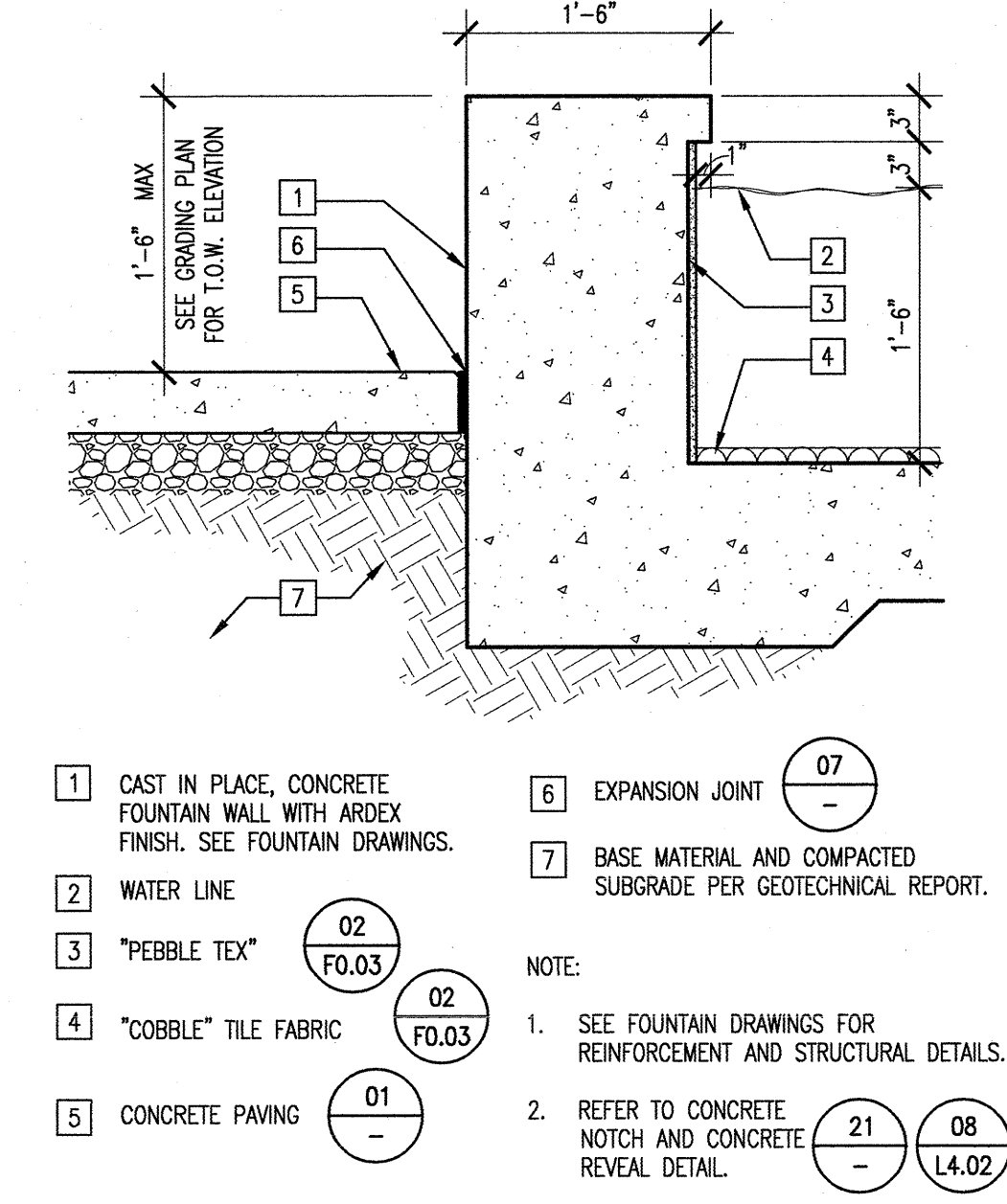

CONCRETE SEATWALL AT FOUNTAIN 1" = 1'-0" CSW-FNTN 13

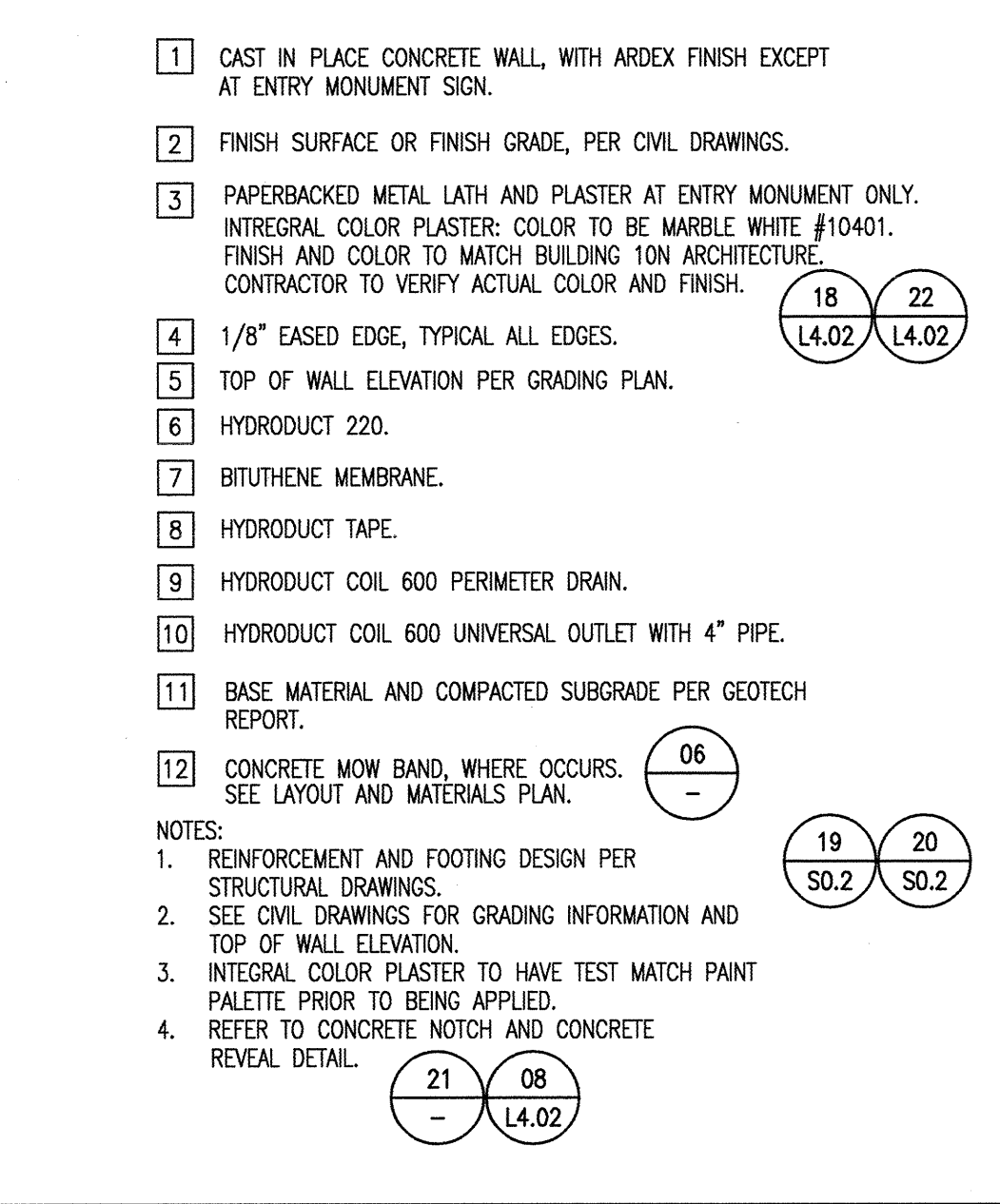

CONCRETE SEATWALL TYPE 2 1" = 1'-0" CSW-T2 10

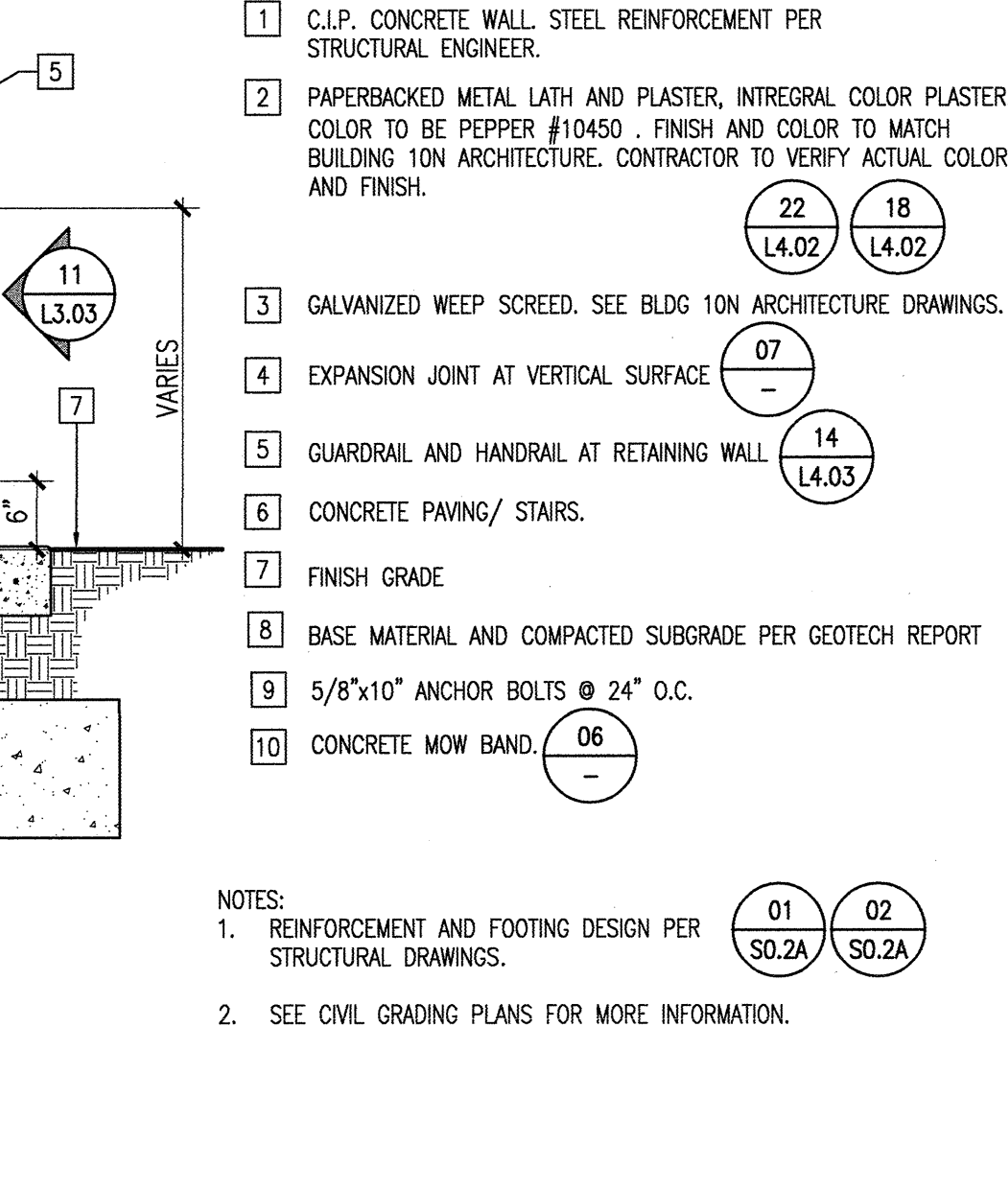

CONCRETE SEATWALL TYPE 3 1" = 1'-0" CSW-T6 16

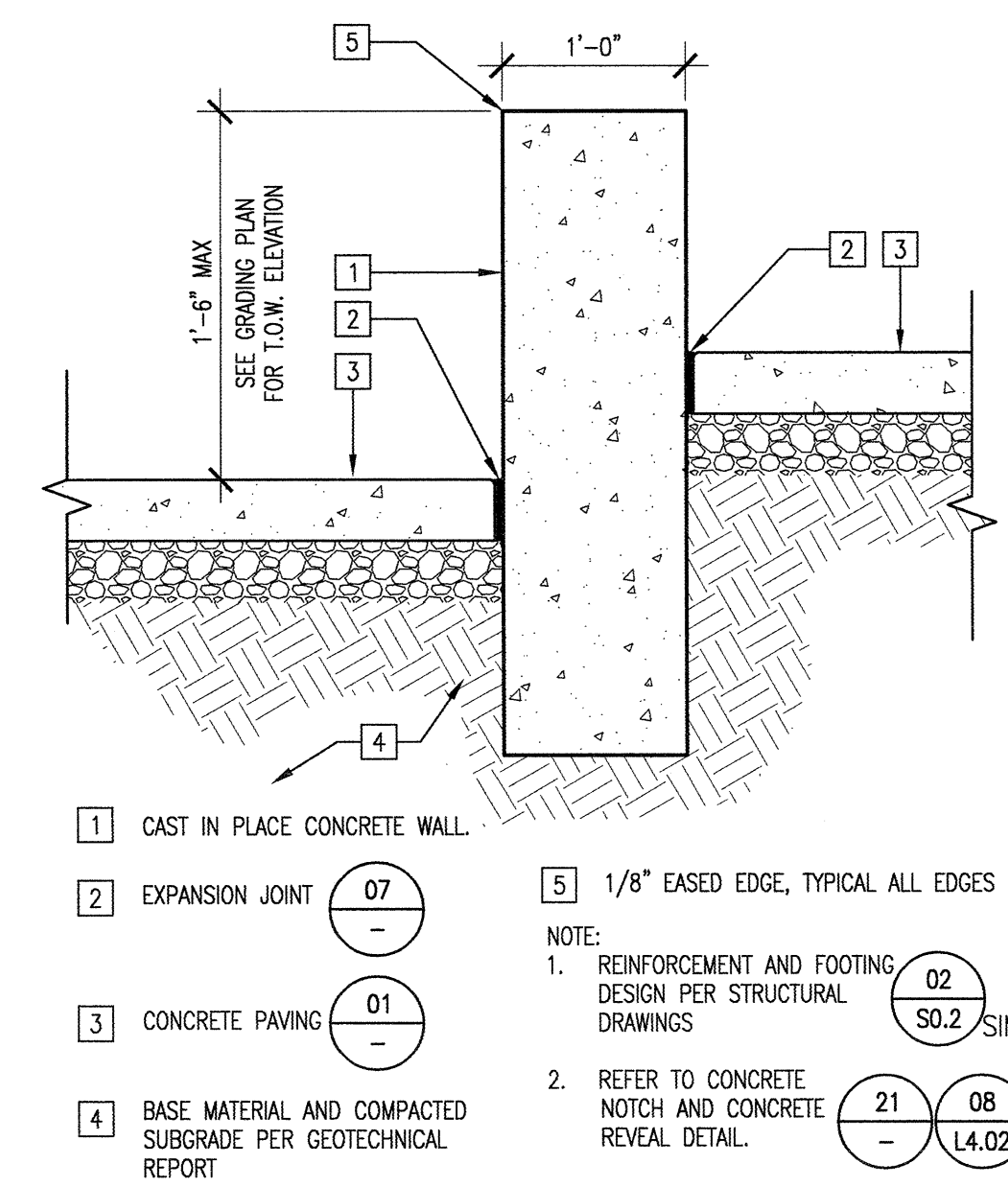

CONCRETE SEATWALL TYPE 3 1" = 1'-0" CSW-T6 16

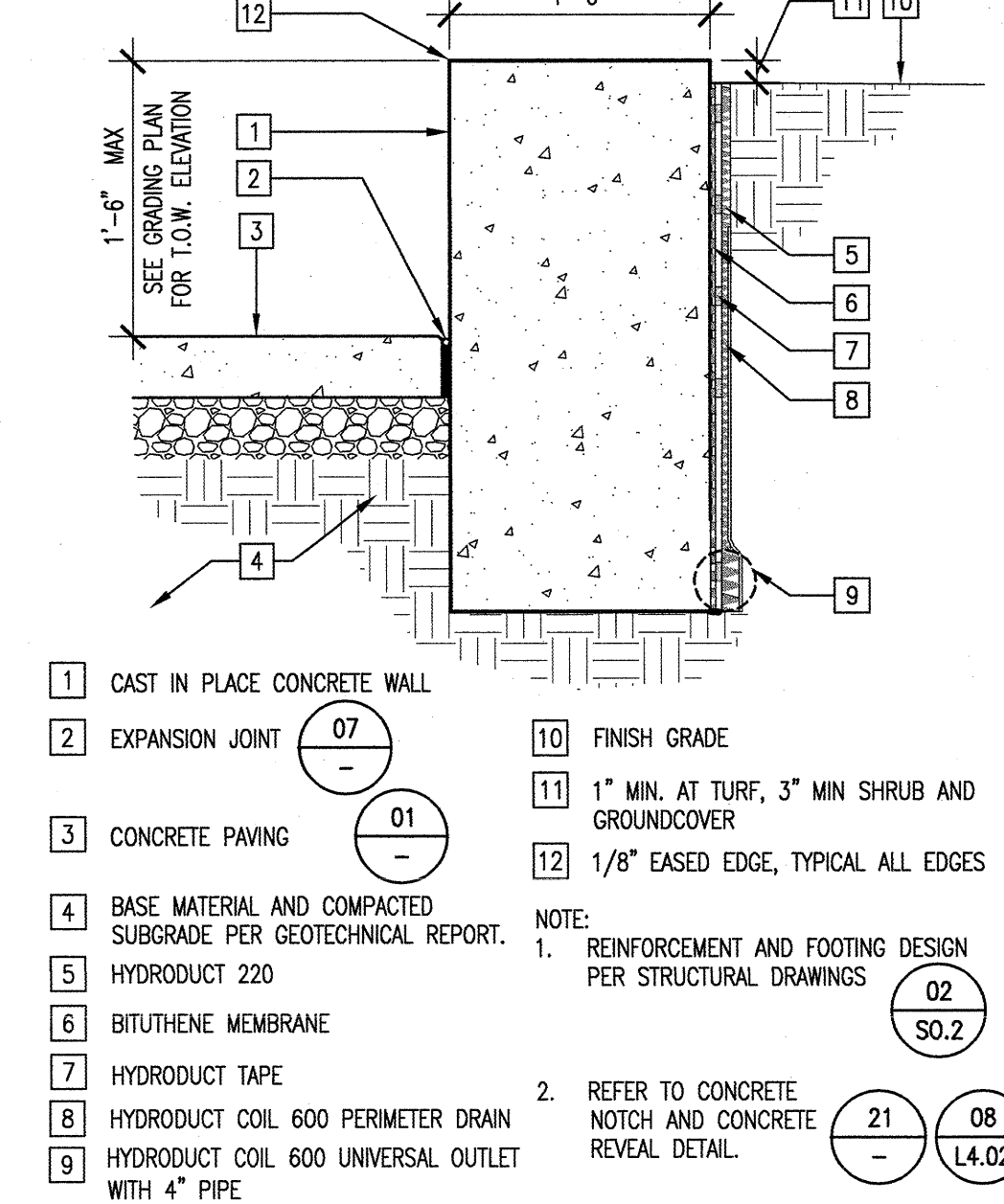

CONCRETE SEATWALL TYPE 4 1" = 1'-0" CSW-T4 09

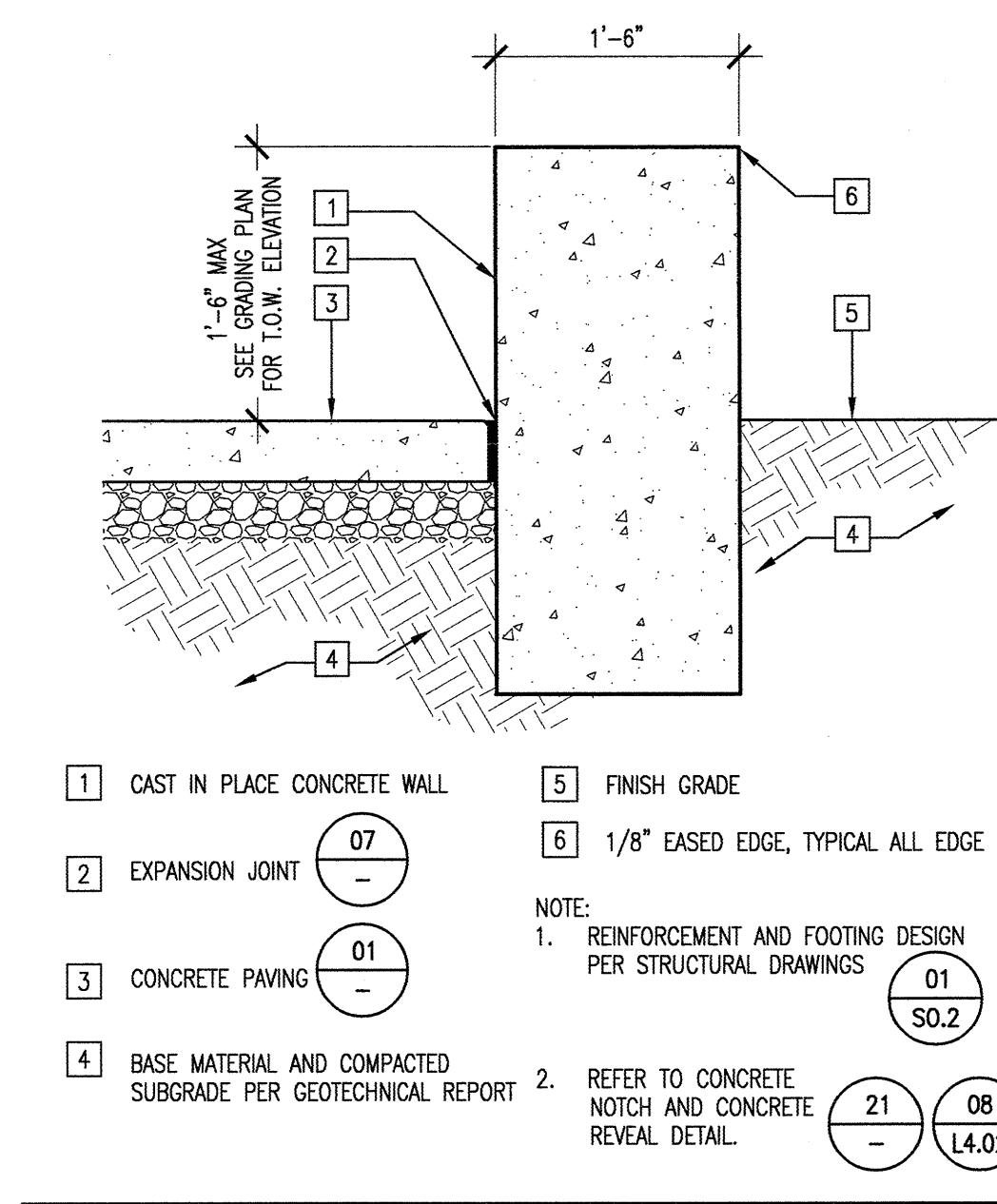

CONCRETE SEATWALL TYPE 2 1" = 1'-0" CSW-T2 10

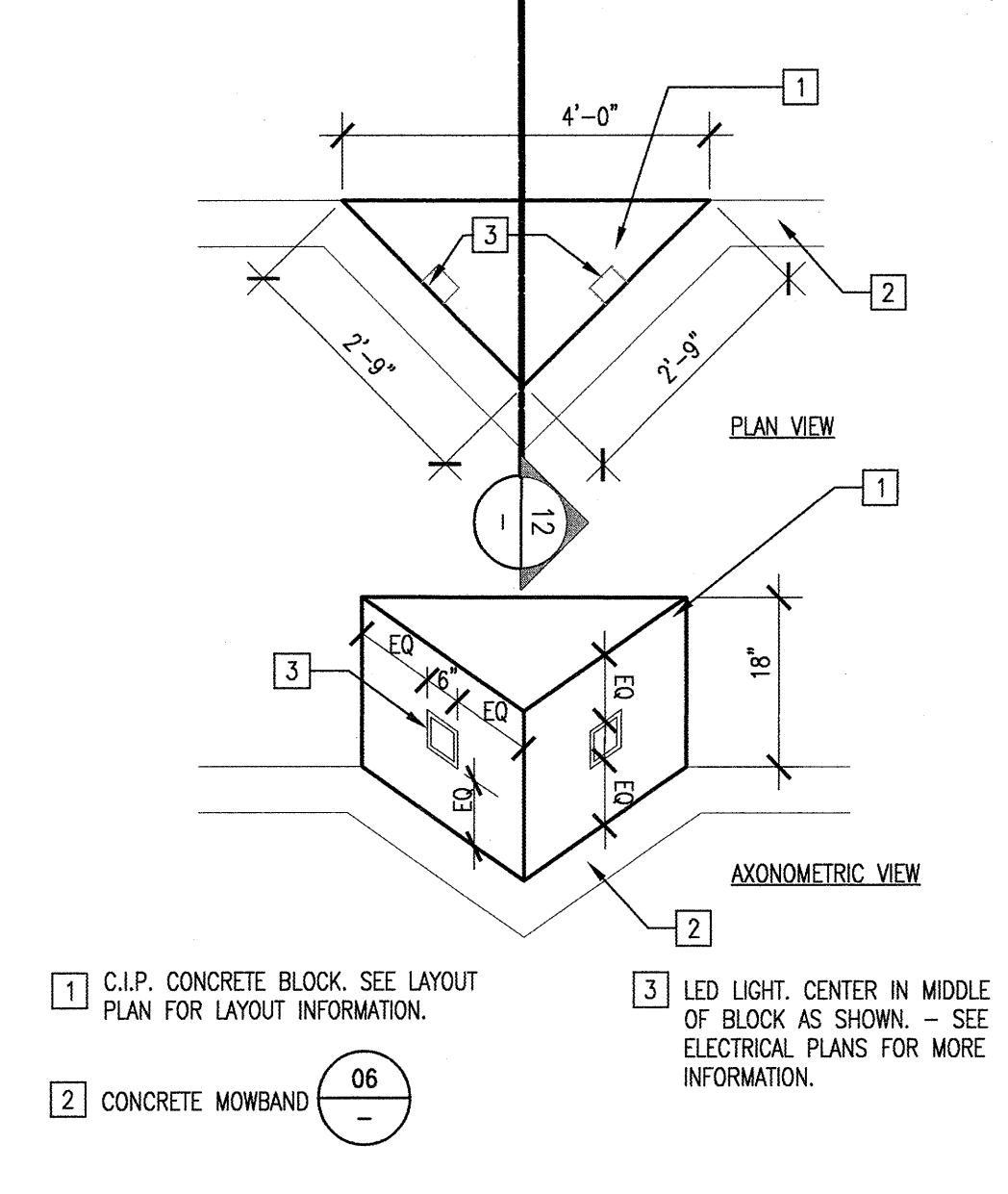

CONCRETE TRIANGULAR SEAT 1/2" = 1'-0" CSW-TRI 11

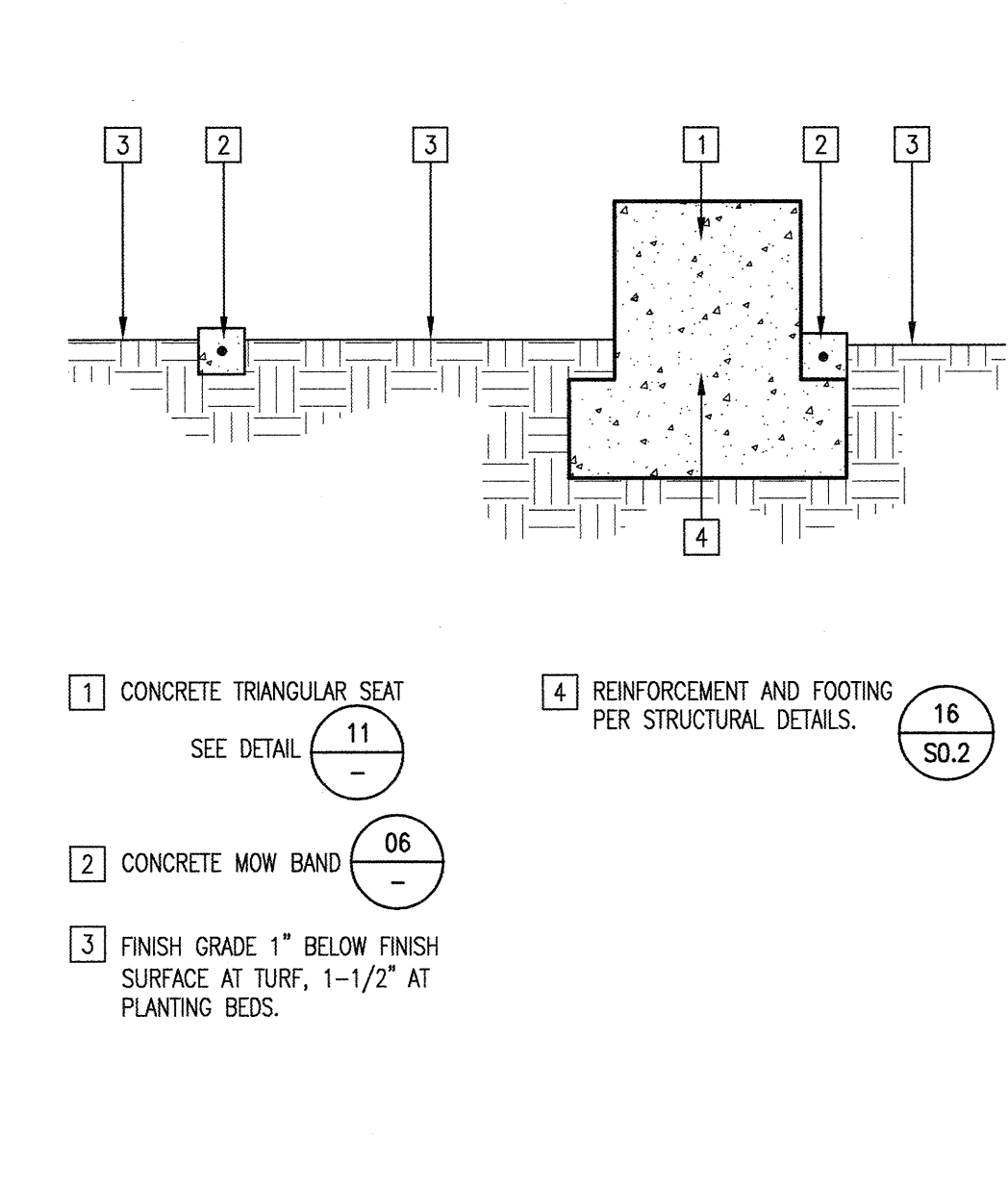

PAVERS AT TRIANGULAR SEAT 1/2" = 1'-0" CSW-TRI2X 12

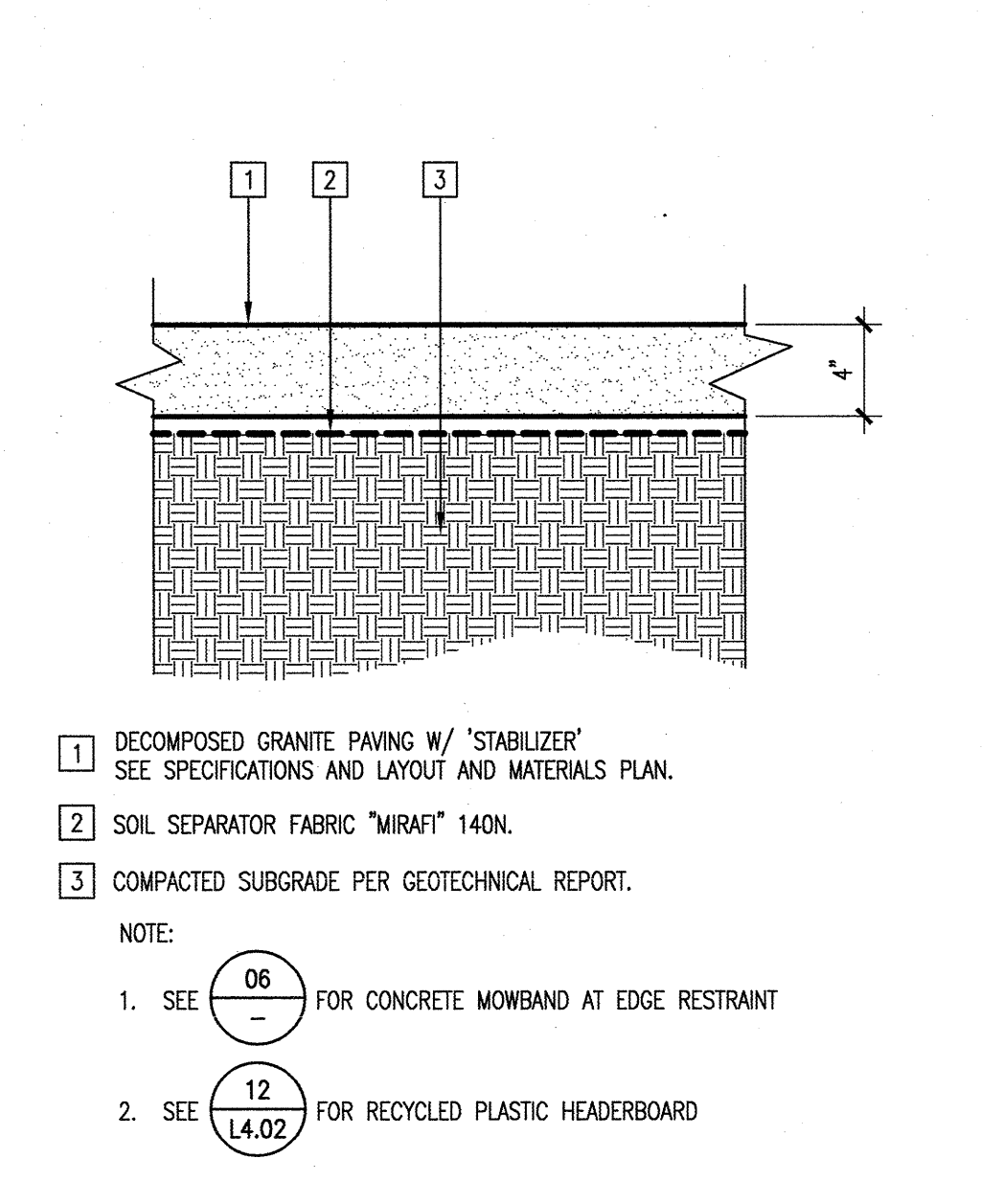

DECOMPOSED GRANITE PAVING 3" = 1'-0" DT02PV16 05

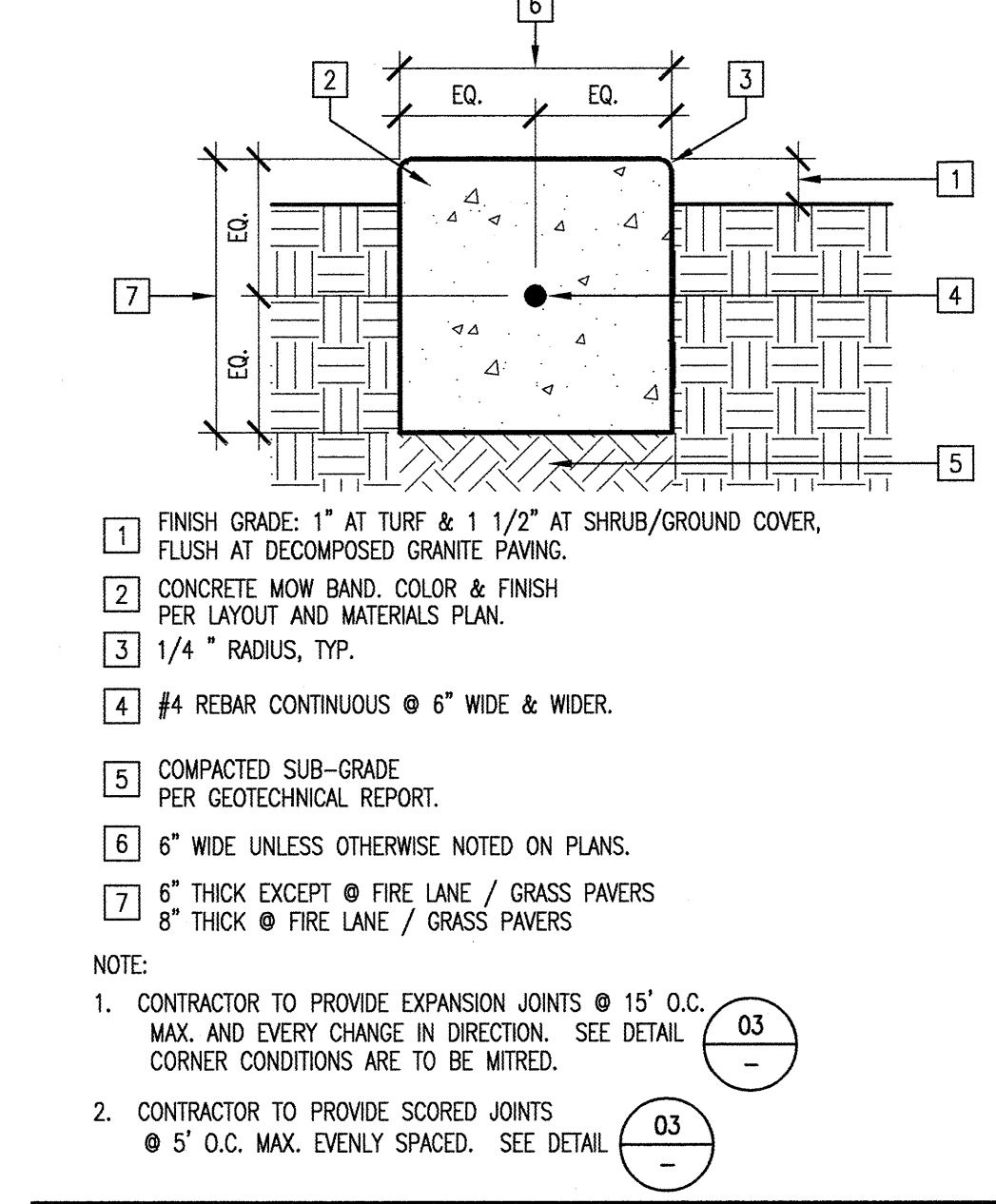

CONCRETE MOW BAND 3" = 1'-0" DT02PV65 06

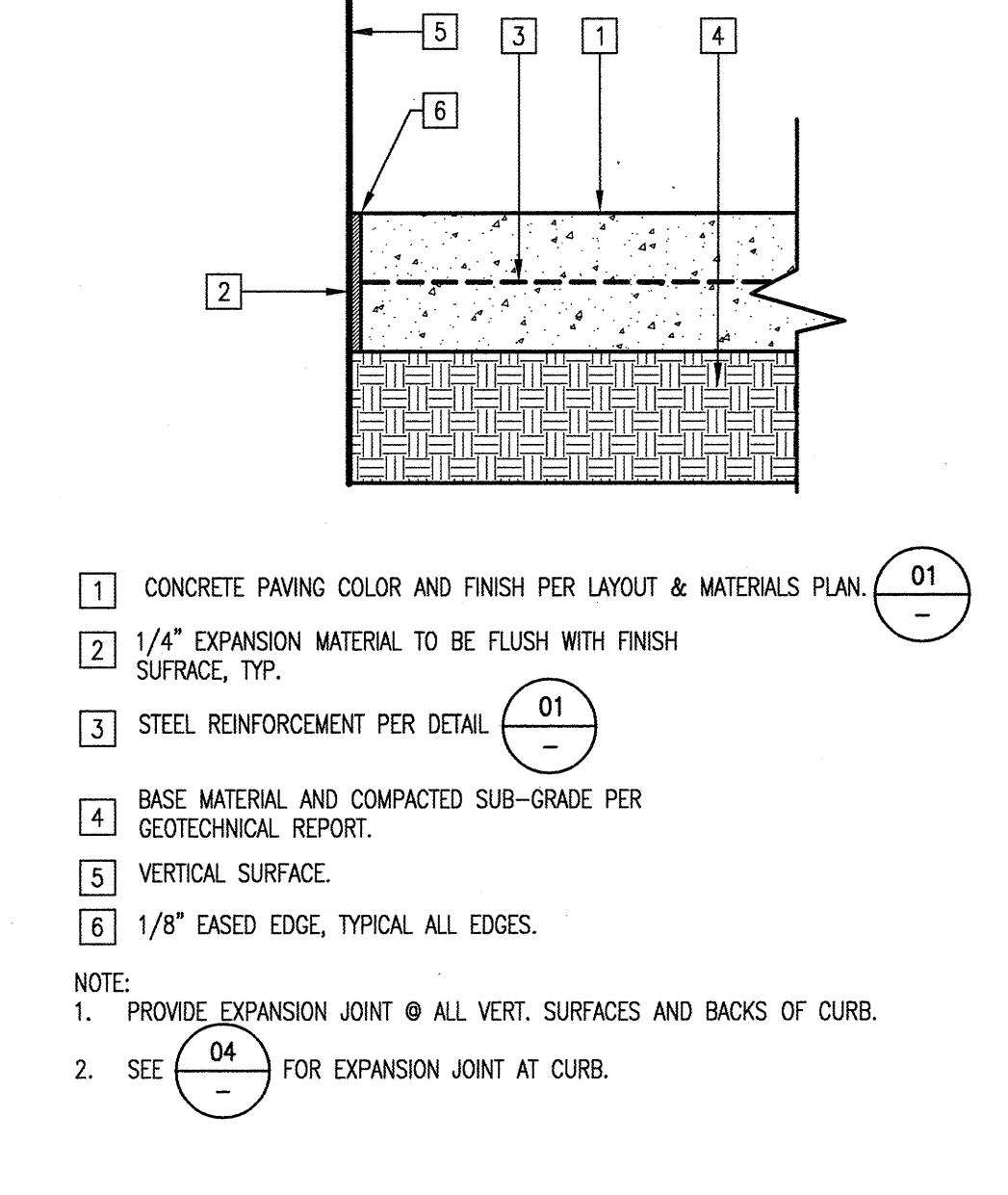

E.J. AT VERTICAL SURFACE 3" = 1'-0" DT02PV35X 07

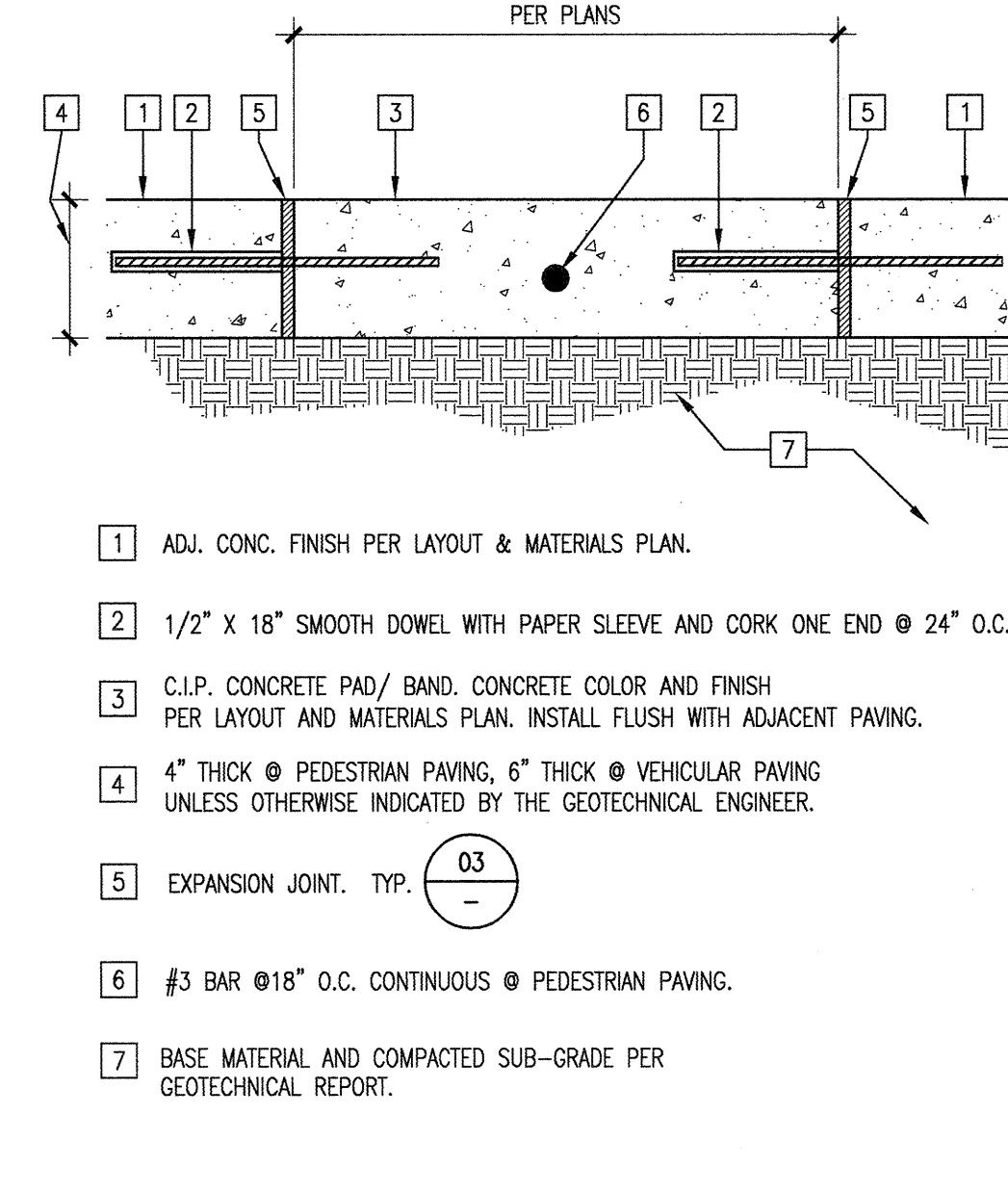

CONCRETE BAND 3" = 1'-0" DT02PV64 08

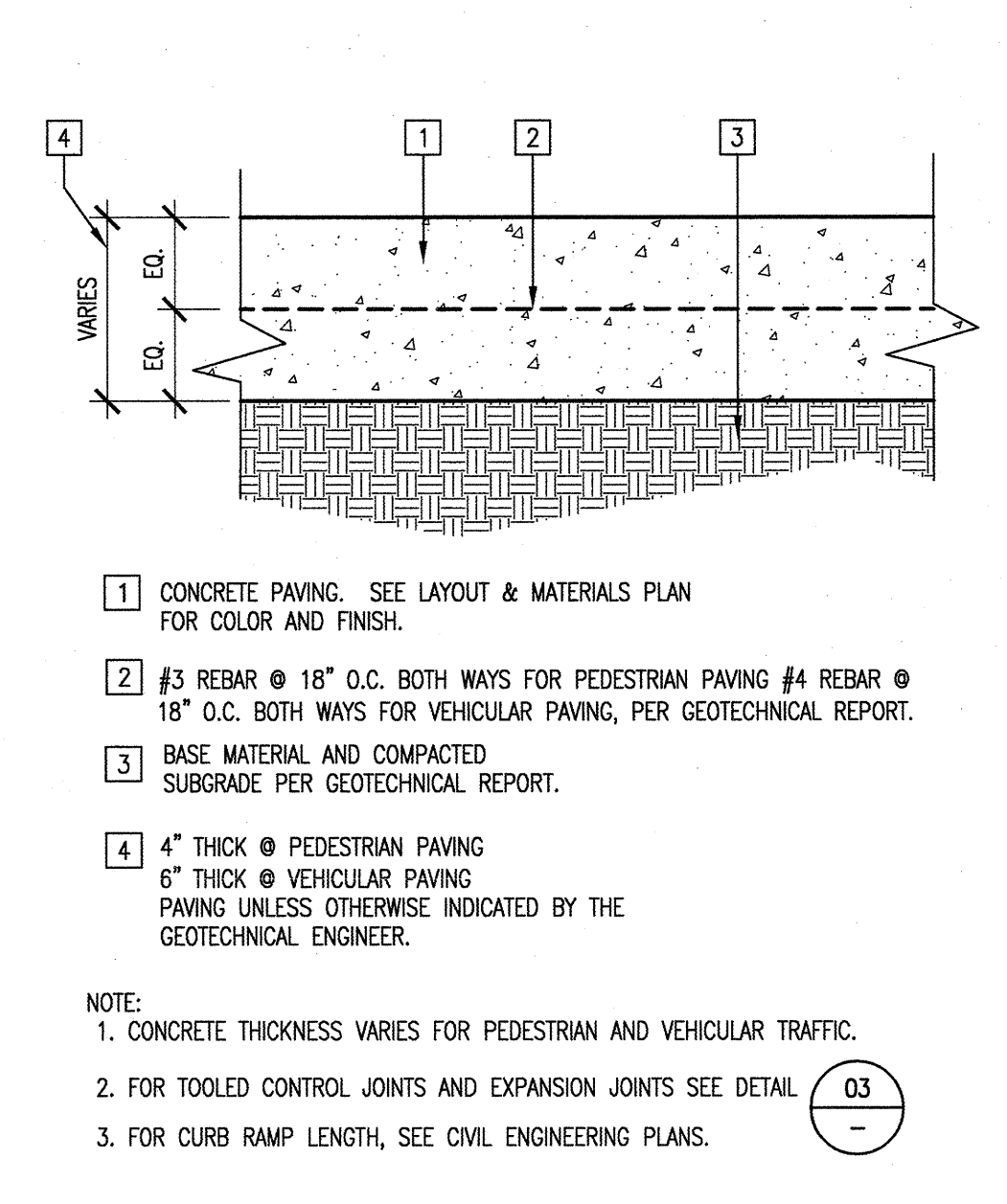

CONCRETE PAVING 3" = 1'-0" DT02PV10 01

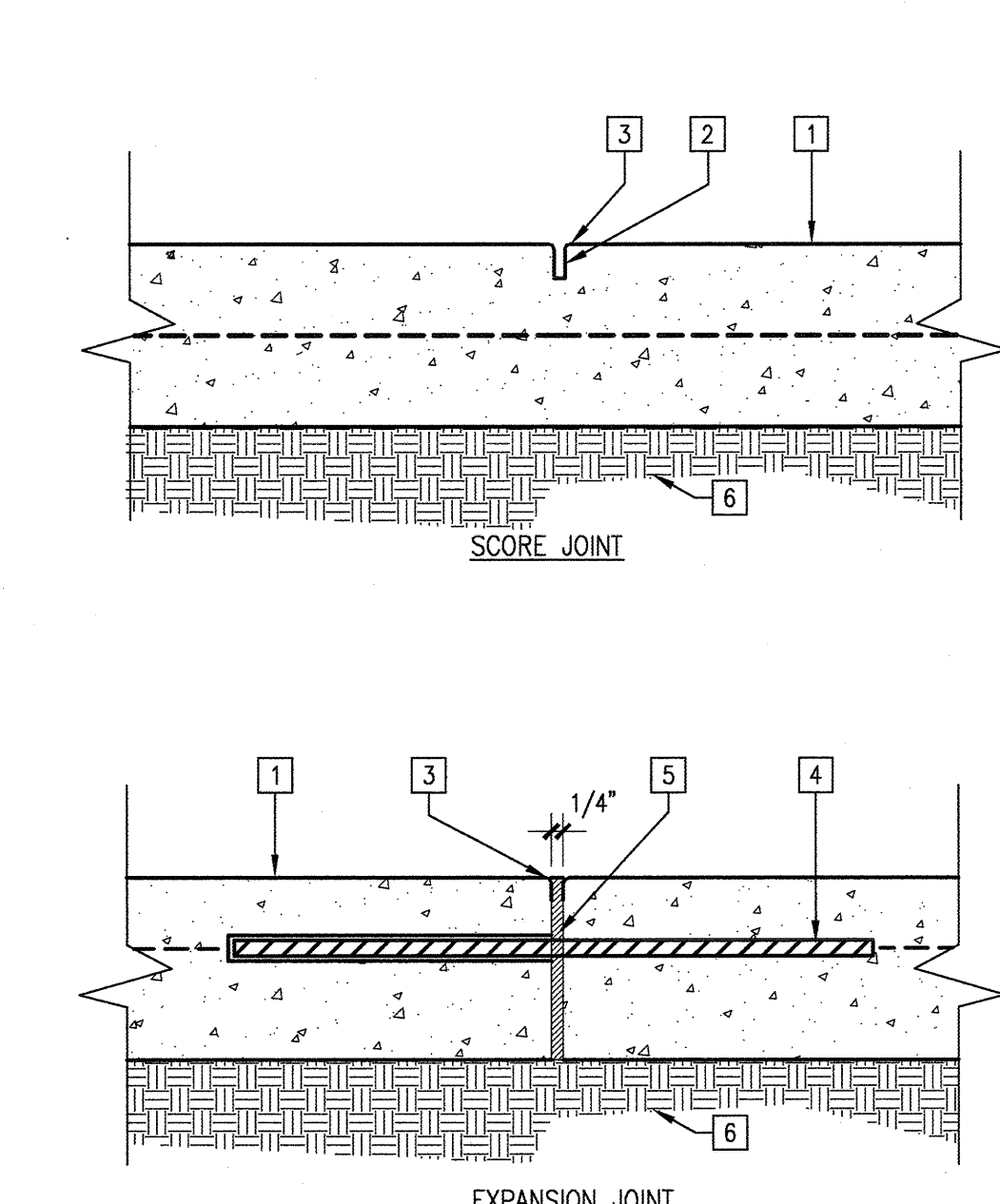

CONCRETE PAVING 3" = 1'-0" DT02PV10 01

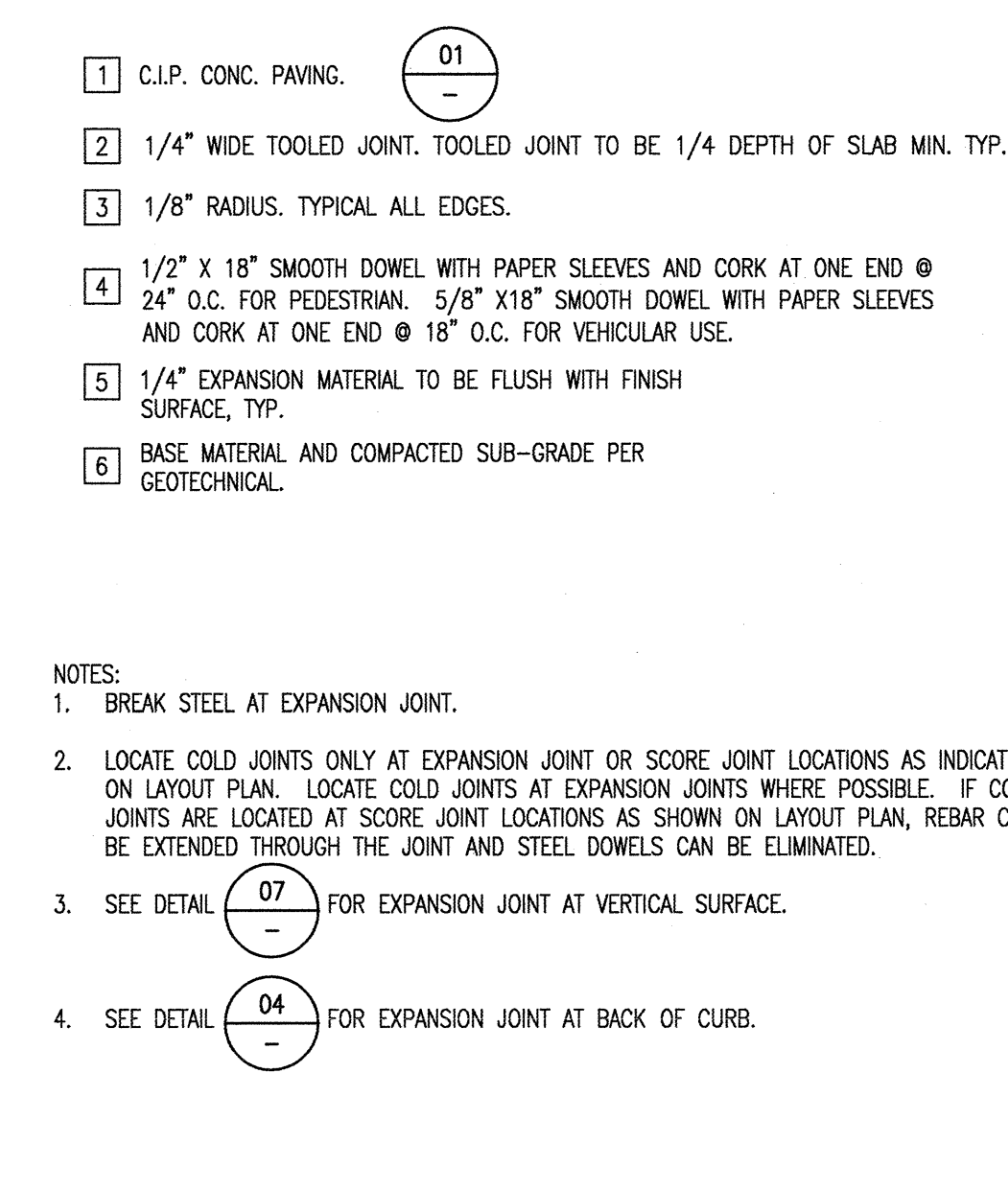

TOOLED CONTROL JOINTS 3" = 1'-0" DT02PV1X2 03

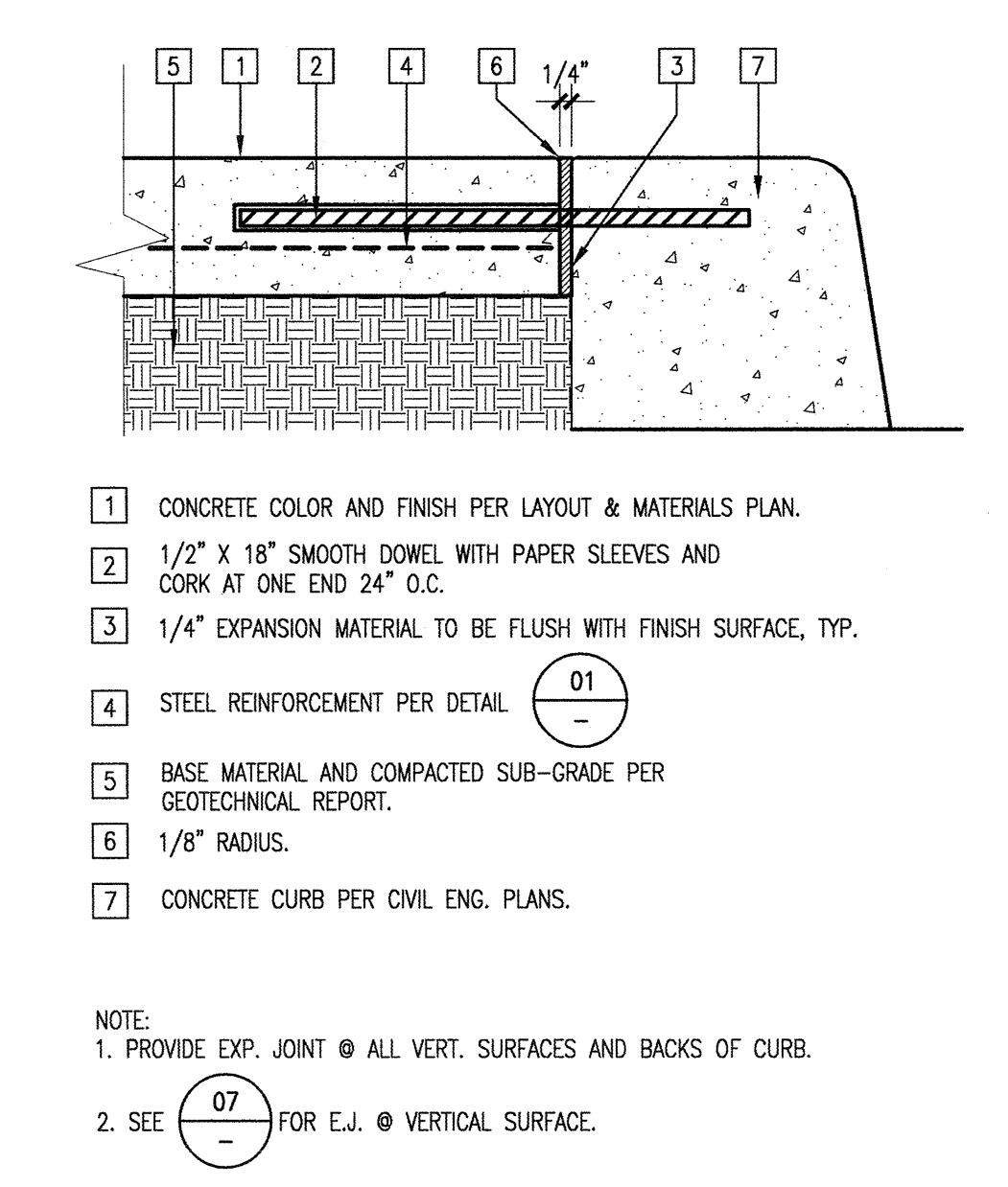

EXPANSION JOINT AT CURB 3" = 1'-0" DT02PV40X 04

Date	Revision	Description

Date	Revision	Description
19 SEPT 2008	SSA SUBMITTAL	
09 APRIL 2009	SSA FINAL	

Job No.	27082.30
Date	06 APRIL 2009
Drawn by	AG, RF
Checked by	BM
Scale	AS SHOWN

CONSTRUCTION DETAILS